

HONDA

Инструкция по эксплуатации (eng)

Лодочные моторы

BF 60 AK1 LRTU

По вопросам продаж и поддержки обращайтесь:

Архангельск (8182)63-90-72
Астана +7(7172)727-132
Белгород (4722)40-23-64
Брянск (4832)59-03-52
Владивосток (423)249-28-31
Волгоград (844)278-03-48
Вологда (8172)26-41-59
Воронеж (473)204-51-73
Екатеринбург (343)384-55-89
Иваново (4932)77-34-06
Ижевск (3412)26-03-58
Казань (843)206-01-48

Калининград (4012)72-03-81
Калуга (4842)92-23-67
Кемерово (3842)65-04-62
Киров (8332)68-02-04
Краснодар (861)203-40-90
Красноярск (391)204-63-61
Курск (4712)77-13-04
Липецк (4742)52-20-81
Магнитогорск (3519)55-03-13
Москва (495)268-04-70
Мурманск (8152)59-64-93
Набережные Челны (8552)20-53-41

Нижний Новгород (831)429-08-12
Новокузнецк (3843)20-46-81
Новосибирск (383)227-86-73
Орел (4862)44-53-42
Оренбург (3532)37-68-04
Пенза (8412)22-31-16
Пермь (342)205-81-47
Ростов-на-Дону (863)308-18-15
Рязань (4912)46-61-64
Самара (846)206-03-16
Санкт-Петербург (812)309-46-40
Саратов (845)249-38-78

Смоленск (4812)29-41-54
Сочи (862)225-72-31
Ставрополь (8652)20-65-13
Тверь (4822)63-31-35
Томск (3822)98-41-53
Тула (4872)74-02-29
Тюмень (3452)66-21-18
Ульяновск (8422)24-23-59
Уфа (347)229-48-12
Челябинск (351)202-03-61
Череповец (8202)49-02-64
Ярославль (4852)69-52-93

www.honda.nt-rt.ru || hdn@nt-rt.ru

INTRODUCTION

Congratulations on your selection of a Honda outboard motor. We are certain you will be pleased with your purchase of one of the finest outboard motors on the market.

We want to help you get the best results from your new outboard motor and to operate it safely. This manual contains information on how to do that; please read it carefully.

As you read this manual you will find information preceded by a

NOTICE symbol. That information is intended to help you avoid damage to your outboard motor, other property, or the environment.

We suggest you read the warranty policy to fully understand its coverage and your responsibilities of ownership.

When your outboard motor needs scheduled maintenance, keep in mind that your Honda Marine dealer is specially trained in servicing Honda outboard motors. Your Honda Marine dealer is dedicated to your satisfaction and will be pleased to answer your questions and concerns.

Best Wishes,
Honda Motor Co., Ltd.

INTRODUCTION

A FEW WORDS ABOUT SAFETY

Your safety and the safety of others are very important. And using this outboard motor safely is an important responsibility.



To help you make informed decisions about safety, we have provided operating procedures and other information on labels and in this manual. This information alerts you to potential hazards that could hurt you or others.

Of course, it is not practical or possible to warn you about all the hazards associated with operating or maintaining an outboard motor. You must use your own good judgment.

You will find important safety information in a variety of forms, including:

- **Safety Labels** — on the outboard motor.
- **Safety Messages** — preceded by a safety alert symbol  and one of three signal words, DANGER, WARNING, or CAUTION.

These signal words mean:

- | | |
|----------------------------------------------------------------------------------------------------|---------------------------------------------------------------------------------------------|
|  DANGER | You WILL be KILLED or SERIOUSLY HURT if you don't follow instructions. |
|  WARNING | You CAN be KILLED or SERIOUSLY HURT if you don't follow instructions. |
|  CAUTION | You CAN be HURT if you don't follow instructions. |

- **Safety Headings** — such as *IMPORTANT SAFETY INFORMATION*.
- **Safety Section** — such as *OUTBOARD MOTOR SAFETY*.
- **Instructions** — how to use this outboard motor correctly and safely.

This entire book is filled with important safety information — please read it carefully.

CONTENTS

OUTBOARD MOTOR SAFETY.....	7	TRL (Trolling) Control Switch	
IMPORTANT SAFETY INFORMATION.....	7	[standard equipment (LHTC and	
SAFETY LABEL LOCATIONS.....	9	LRTB types), [optional equipment	
CONTROLS AND FEATURES	13	(except LHTC and LRTB types)].....	32
CONTROL AND FEATURE		Tilt Lock Lever	33
IDENTIFICATION CODES	13	Engine Cover Latches	33
COMPONENT AND CONTROL LOCATIONS	14	Trim Tab.....	34
CONTROLS.....	22	INSTRUMENTS.....	35
LHT Type (tiller handle)		Trim Meter (optional equipment)	35
Ignition Switch.....	22	Tachometer (optional equipment).....	35
Emergency Stop Switch Clip and		Digital Tachometer [optional equipment	
Emergency Stop Switch.....	22	(LRT and XRT types)].....	35
Throttle Grip.....	23	Digital Speedometer [optional equipment	
Throttle Friction Adjuster	24	(LRT and XRT types)].....	36
Gearshift Lever	24	Rudder Meter [standard equipment	
Steering Friction Adjuster	25	(BFP60A LRTB type)],	
LRT and XRT Types (remote control)		[optional equipment (other LRT and	
Side-Mount Control Type (optional equipment)...	26	XRT types)]	36
Ignition Switch.....	26	Fuel Gauge (optional equipment)	36
Emergency Stop Switch Clip and Emergency		INDICATORS.....	37
Stop Switch	27	Alternator (ACG) Indicator.....	37
Gearshift/Throttle Control Lever.....	28	Malfunction Indicator	37
Fast Idle Lever.....	29	Oil Pressure Indicator.....	38
Common Controls.....	30	Overheat Indicator.....	39
Power Trim/Tilt Switch	30	Cooling System Indicator	39
Power Tilt Switch (engine pan)	31		
Manual Relief Valve.....	32		

CONTENTS

OTHER FEATURES	40	GEARSHIFT AND	
Overrev Limiter.....	40	THROTTLE OPERATION	62
Portable Fuel Tank (optional equipment)	40	LHT Type (tiller handle).....	62
Fuel Filler Cap Vent Knob (optional equipment)..	41	LRT and XRT Types (remote control)	
Fuel Priming Bulb.....	41	Side-Mount Control Type.....	63
NMEA Interface Coupler.....	41	STEERING	64
Anodes.....	42	LHT Type (tiller handle).....	64
BEFORE OPERATION.....	43	Steering Friction Adjuster	64
ARE YOU READY TO GET UNDER WAY?.....	43	LRT and XRT Types (remote control)	64
IS YOUR OUTBOARD MOTOR		CRUISING	65
READY TO GO?	43	Trolling Speed Control	
Tiller Handle Height/Angle Adjustment		[standard equipment (LHTC and	
(LHT type)	45	LRTB types)], [optional equipment	
OPERATION	46	(except LHTC and LRTB types)].....	67
SAFE OPERATING PRECAUTIONS	46	TRIM TAB.....	68
BREAK-IN PROCEDURE.....	46	SHALLOW WATER OPERATION	69
PORTABLE FUEL TANK (optional equipment).....	47	MOORING, BEACHING, LAUNCHING.....	70
FUEL HOSE CONNECTIONS.....	48	SERVICING YOUR OUTBOARD MOTOR.....	72
FUEL PRIMING.....	49	THE IMPORTANCE OF MAINTENANCE.....	72
STARTING THE ENGINE	50	MAINTENANCE SAFETY	73
LHT Type (tiller handle).....	50	TOOL KIT and OWNER'S MANUAL	74
LRT and XRT Types (remote control)		EMERGENCY STARTER ROPE	74
Side-Mount Control Type.....	53	MAINTENANCE SCHEDULE	75
EMERGENCY STARTING.....	56	TRIM TAB ADJUSTMENT	77
STOPPING THE ENGINE.....	59	MANUAL RELIEF VALVE.....	79
Emergency Engine Stopping	59		
Normal Engine Stopping.....	60		

CONTENTS

ENGINE COVER REMOVAL AND INSTALLATION	79	TRANSPORTING	103
Engine Oil Level Check.....	80	WITH OUTBOARD MOTOR INSTALLED ON BOAT	103
Engine Oil Change	81	WITH OUTBOARD MOTOR REMOVED FROM BOAT	103
Engine Oil Recommendations	82	TAKING CARE OF UNEXPECTED PROBLEMS.....	104
Spark Plug Service	83	ENGINE WILL NOT START.....	104
Lubrication Points	85	HARD STARTING OR STALLS AFTER STARTING	107
REFUELING.....	87	ENGINE OVERHEATS	108
FUEL RECOMMENDATIONS.....	88	FUSES.....	109
Fuel Filter/Water Separator Inspection and Service.....	89	Electric Starter Will Not Operate.....	109
Portable Fuel Tank and Tank Filter Cleaning (optional equipment).....	92	Battery Will Not Charge	109
Anode Replacement	93	Fuse Replacment	110
Propeller Replacement	94	OIL PRESSURE INDICATOR GOES OFF AND ENGINE SPEED IS LIMITED	112
STORAGE	96	OVERHEAT INDICATOR COMES ON AND ENGINE SPEED IS LIMITED	113
STORAGE PREPARATION	96	SUBMERGED MOTOR	115
Cleaning and Flushing	96		
Fuel.....	98		
Engine Oil	101		
HOISTING THE OUTBOARD MOTOR.....	101		
STORAGE PRECAUTIONS	101		
REMOVAL FROM STORAGE.....	102		

CONTENTS

TECHNICAL AND CONSUMER	
INFORMATION.....	117
TECHNICAL INFORMATION.....	117
Serial Number Locations	117
Battery	118
Emission Control System Information	118
Star Label	121
Specifications.....	123
CONSUMER INFORMATION	126
Honda publications	126
Customer Service Information.....	126
Warranty Statements	129
Distributor's Limited Warranty	129
Emission Control System Warranty	133
Distributor's Warranty	137
INDEX.....	140

OUTBOARD MOTOR SAFETY

IMPORTANT SAFETY INFORMATION

The Honda BF60A/BFP60A outboard motors are designed for use with boats that have a suitable manufacturer's power recommendation. Other uses can result in injury to the operator or damage to the outboard motor and other property.

Most injuries or property damage can be prevented if you follow all instructions in this manual and on the outboard motor. The most common hazards are discussed in this chapter, along with the best way to protect yourself and others.

Operator Responsibility

- It is the operator's responsibility to provide the necessary safeguards to protect people and property. Know how to stop the engine quickly in case of emergency. Understand the use of all controls.
 - Stop the engine immediately if anyone falls overboard, and do not run the engine while the boat is near anyone in the water.
 - Always stop the engine if you must leave the controls for any reason.
- Attach the emergency stop switch lanyard securely to the operator.
 - Always wear a PFD (Personal Flotation Device) while on the boat.
 - Familiarize yourself with all laws and regulations relating to boating and the use of outboard motors.
 - Be sure that anyone who operates the outboard motor receives proper instruction.
 - Be sure the outboard motor is properly mounted on the boat.
 - Do not remove the engine cover while the engine is running.

OUTBOARD MOTOR SAFETY

Refuel With Care

- Gasoline is extremely flammable, and gasoline vapor can explode. Refuel outdoors, in a well-ventilated area, with the engine stopped. Never smoke near gasoline, and keep other flames and sparks away.
- Refuel carefully to avoid spilling fuel. Avoid overfilling the fuel tank.
- After refueling, tighten the filler cap securely. If any fuel is spilled, make sure the area is dry before starting the engine.

Carbon Monoxide Hazard

Exhaust contains poisonous carbon monoxide, a colorless, odorless gas. Breathing carbon monoxide can cause loss of consciousness and may lead to death.

If you run the engine in an area that is confined, or even partly enclosed, the air you breathe could contain a dangerous amount of exhaust gas.

Never run your outboard inside a garage or other enclosure.

OUTBOARD MOTOR SAFETY

SAFETY LABEL LOCATION

LRTA, LRTB and XRTA Types

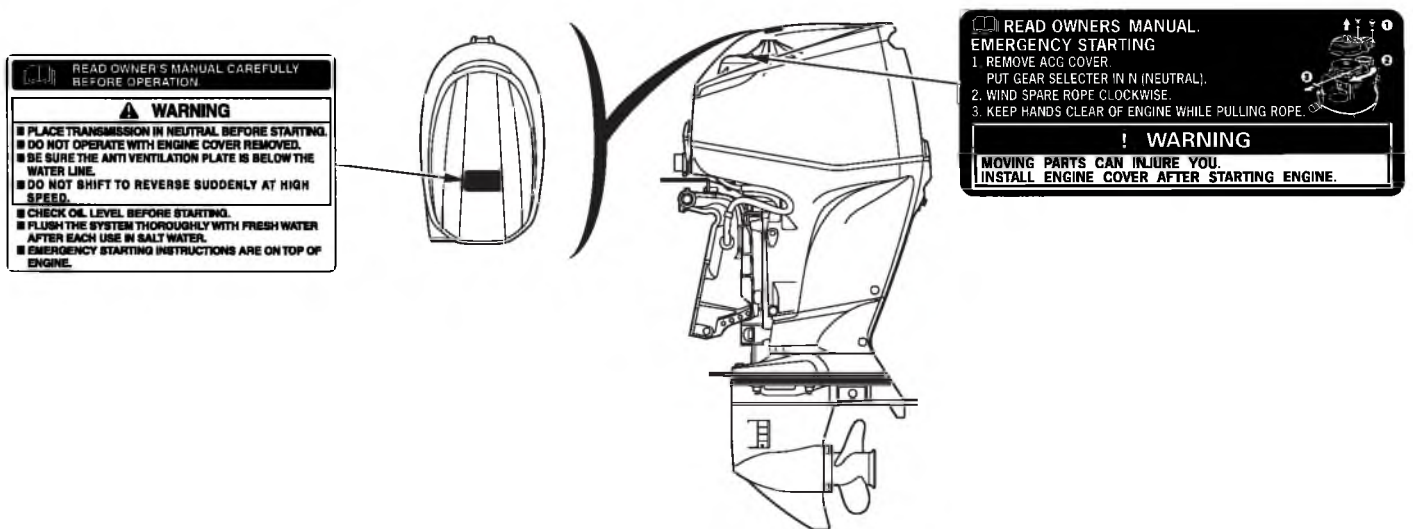

The label shown here contains important safety information. Please read it carefully. This label is considered a permanent part of your outboard motor. If the label comes off or becomes hard to read, contact an authorized Honda Marine dealer for a replacement.

OUTBOARD MOTOR SAFETY

LHTC and LRTC Types

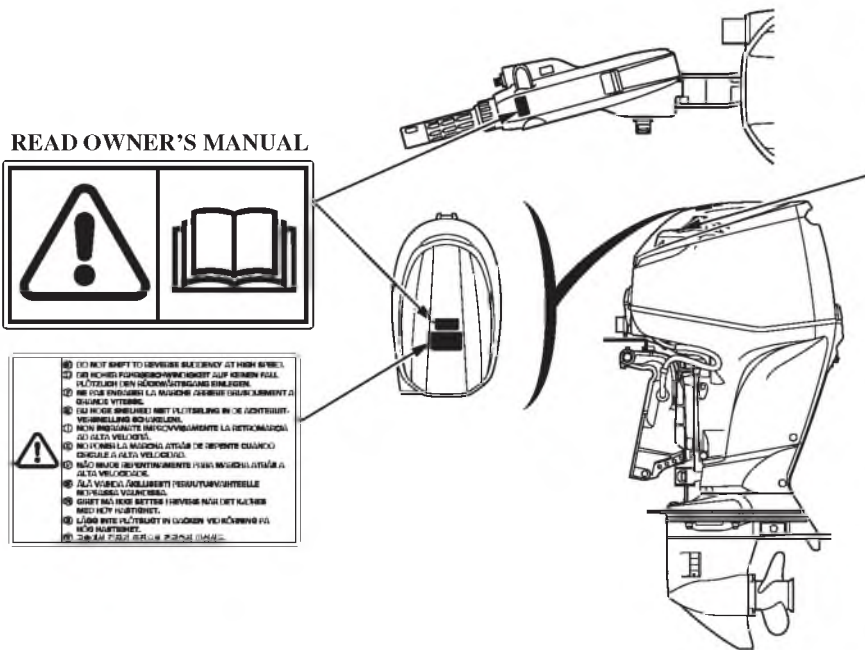

READ OWNER'S MANUAL EMERGENCY ENGINE STARTING

**READ OWNERS MANUAL.
EMERGENCY STARTING**

1. REMOVE AGG COVER.
2. PUT GEAR SELECTOR IN N (NEUTRAL).
3. WIND SPARE ROPE CLOCKWISE.
3. KEEP HANDS CLEAR OF ENGINE WHILE PULLING ROPE.

! WARNING
MOVING PARTS CAN INJURE YOU.
INSTALL ENGINE COVER AFTER STARTING ENGINE.

**LISEZ LE MANUEL DU PROPRIÉTAIRE
MISE EN MARCHÉ D'URGENCE**

1. ENLEVEZ LE COUVERCLE AGG.
2. METTEZ LE SELECTEUR DE VITESSE AU NEUTRE "N".
2. ENROULEZ LA CORDE DE SECOURS VERS LA GAUCHE.
3. NE TOUCHEZ PAS AU MOTEUR AVEC LES MAINS PENDANT QUE VOUS TIREZ LA CORDE.

! AVERTISSEMENT
LES PIÉCES MOBILES PEUVENT VOUS BLESSER.
METTEZ LE COUVERCLE DU MOTEUR EN PLACE APRÉS LA MISE EN MARCHÉ.

* These labels come with the outboard motor.

The label shown here contains important safety information. Please read it carefully. This label is considered a permanent part of your outboard motor. If the label comes off or becomes hard to read, contact an authorized Honda Marine dealer for a replacement.

OUTBOARD MOTOR SAFETY

PORTABLE FUEL TANK (optional equipment)

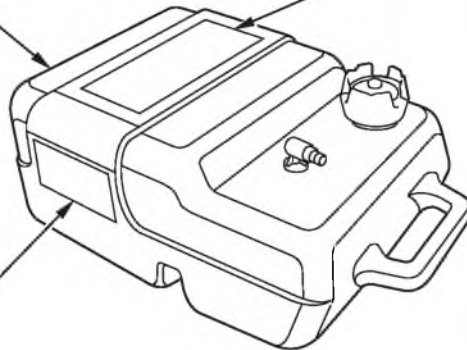
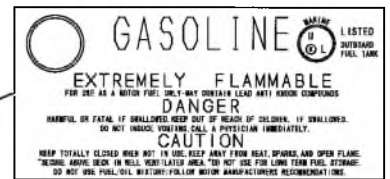

FUEL CAUTION

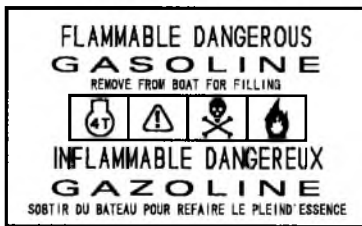

OUTBOARD MOTOR SAFETY

LHTC and LRTC Types



- Honda outboard motor is designed to give safe and dependable service if operated according to instructions. Read and understand the Owner's Manual before operating the outboard motor. Failure to do so could result in personal injury or equipment damage.



- Gasoline is harmful or fatal if swallowed. Keep the fuel tank out of reach of children.
- Gasoline is extremely flammable and is explosive under certain conditions. Refuel in a well-ventilated area with the engine stopped.
- Do not smoke or allow flames or sparks where the engine is refueled or where gasoline is stored.
- Do not overfill the fuel tank. After refueling make sure that the fuel tank cap is closed properly and securely.

- Be careful not to spill any fuel while refueling. Spilled fuel or fuel vapor may ignite. If any fuel is spilled, make sure that the area is dry before starting the engine.

CONTROLS AND FEATURES

CONTROL AND FEATURE IDENTIFICATION CODES

Model	BF60A				BFP60A			
	LHTC	LRTA	LRTC	XRTA	LRTA	LRTB	LRTC	XRTA
Type								
Shaft Length	L	●	●	●		●	●	●
	X				●			●
Tiller Handle	●							
Remote Control		●	●	●	●	●	●	●
Power Trim/Tilt	●	●	●	●	●	●	●	●
Tachometer	*	*	*	*	*	*	*	*
Trim Meter	*	*	*	*	*	*	*	*
Rudder Meter		*	*	*	*	●	*	*
Tilt Limit Mechanism		*	*	*	*	●	*	*
Portable Fuel Tank (25 L)	*	*	*	*	*	*	*	*
TRL (Trolling) Control Switch	●	*	*	*	*	●	*	*
50° Steering Angle Rod	—	*	*	*	●	●	●	●

*: Optional equipment

Refer to this chart for an explanation of the Type Codes used in this manual to identify control and feature applications.

TYPE CODE (Example)

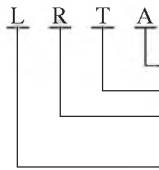

Destination: A=American, B=American (optional applications equipped type), C=Canadian

T=Power Trim/Tilt

H=Tiller Handle

R=Remote Control

BF60A: L=20.5 in (521 mm) (Long Shaft), X=25.5 in (648 mm) (Extra Long Shaft)

BFP60A: L=20.9 in (531 mm) (Long Shaft), X=25.9 in (658 mm) (Extra Long Shaft)

CONTROLS AND FEATURES

COMPONENT AND CONTROL LOCATIONS

LHT Type (tiller handle)

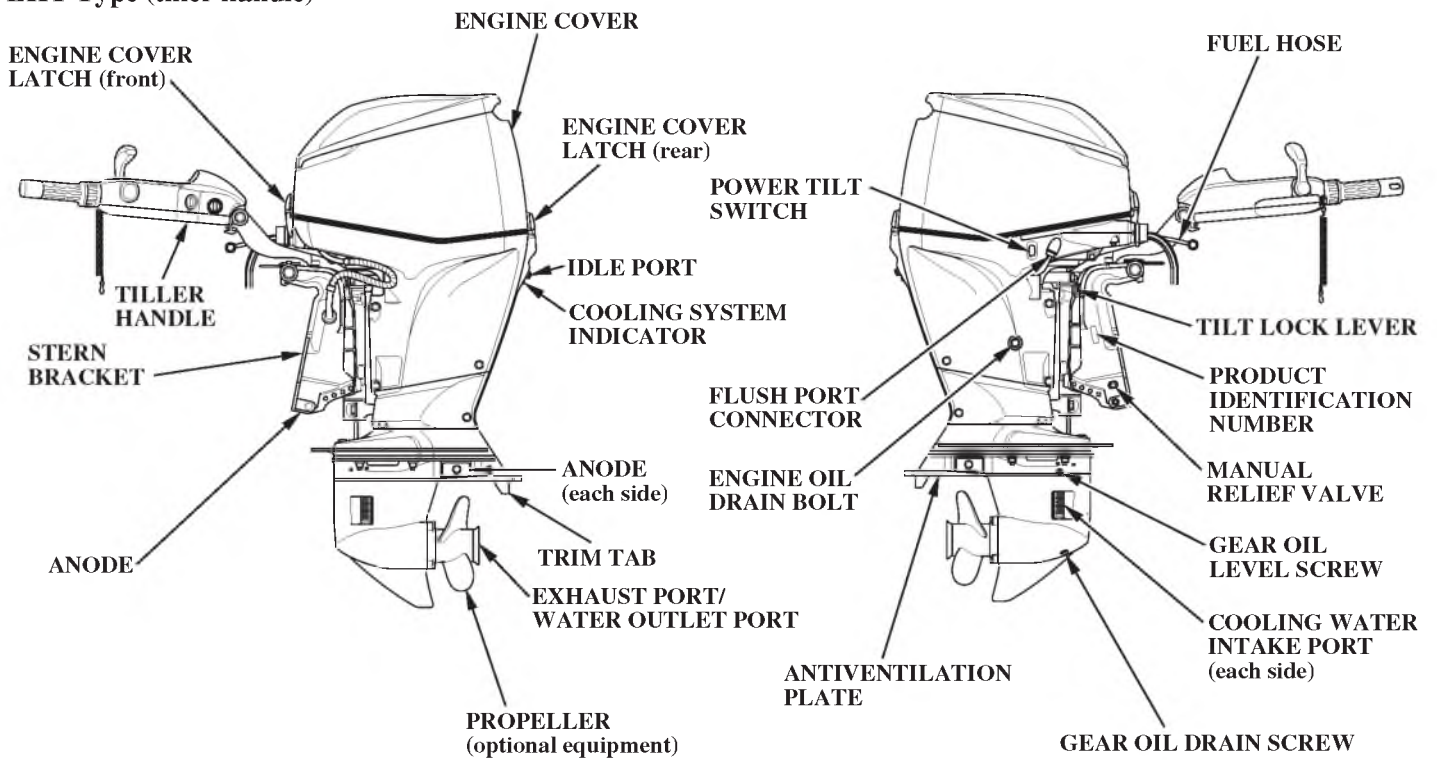

CONTROLS AND FEATURES

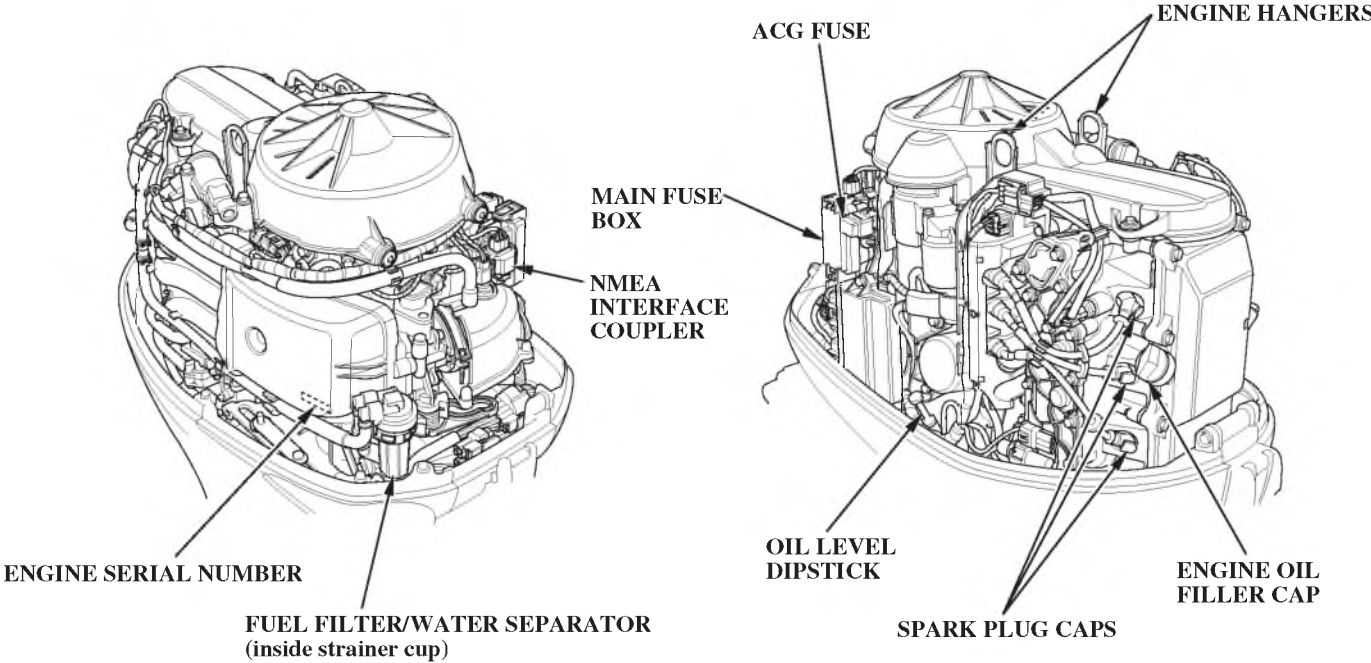

CONTROLS AND FEATURES

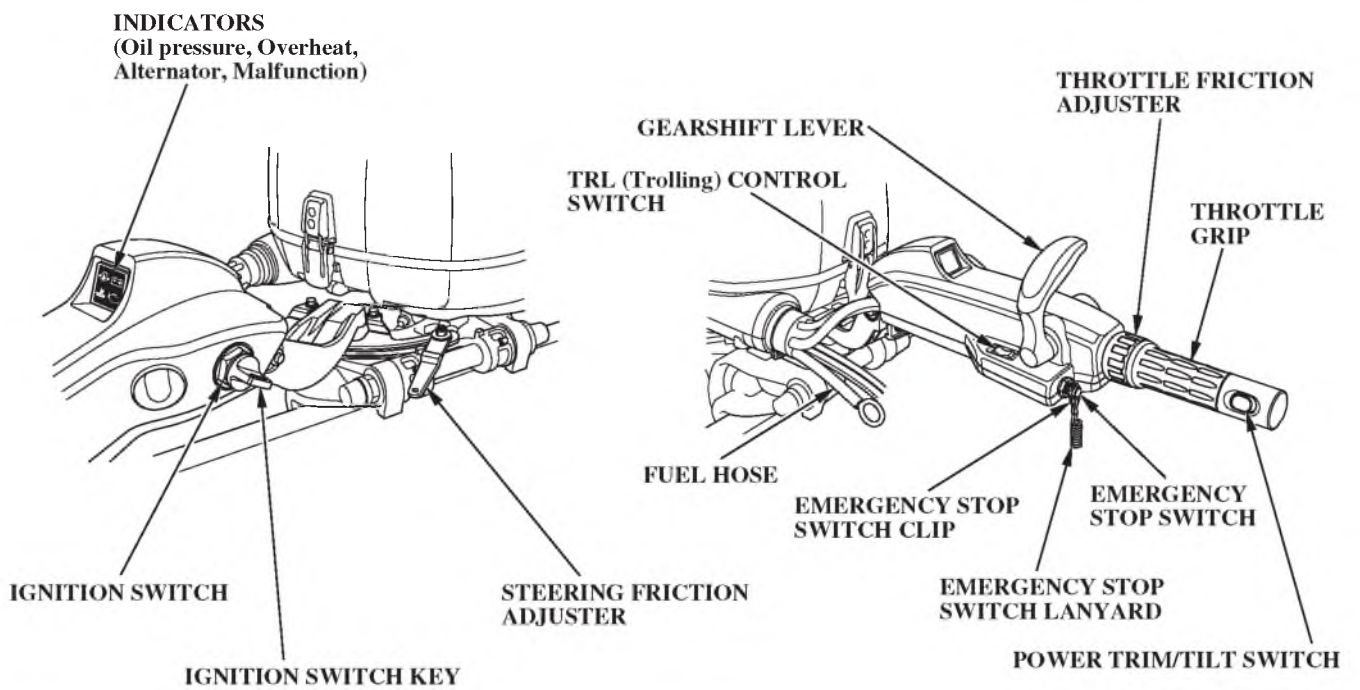

CONTROLS AND FEATURES

LRT and XRT Types (remote control)

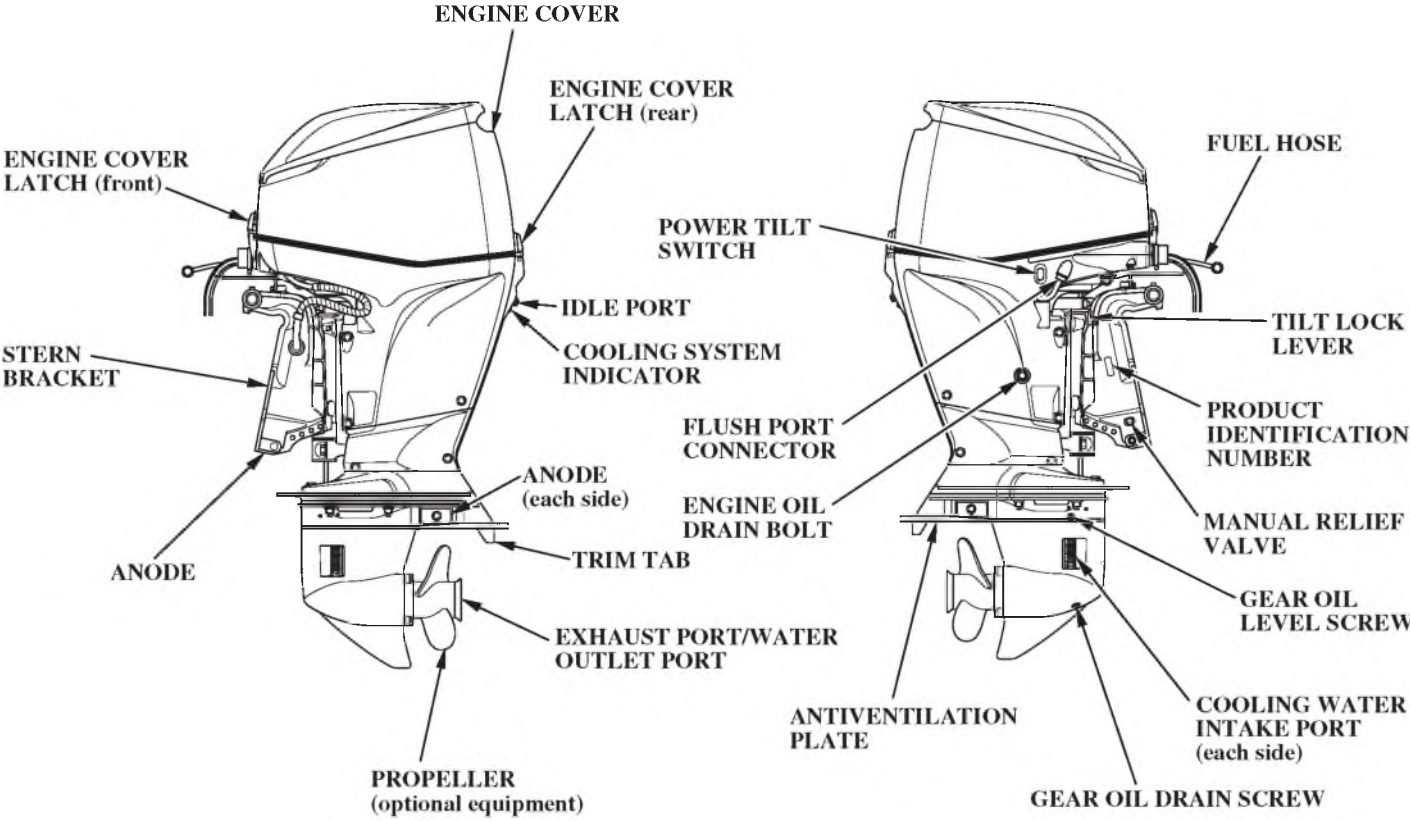

CONTROLS AND FEATURES

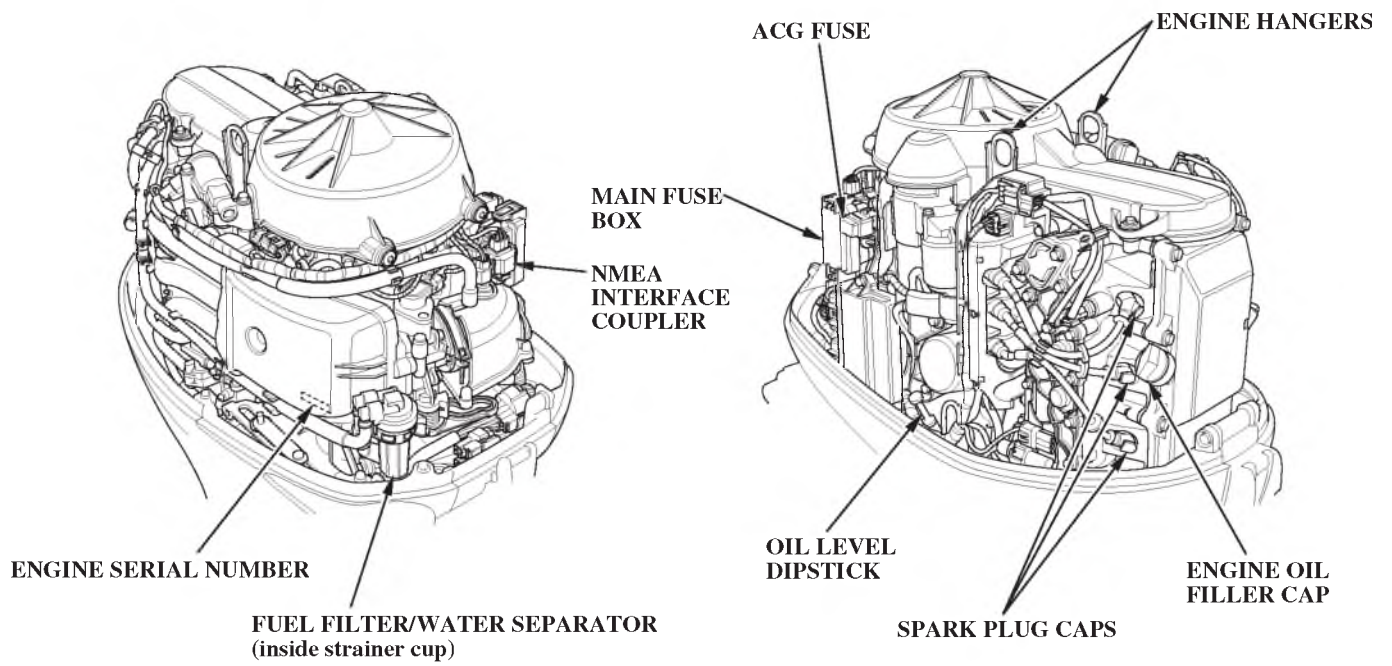

CONTROLS AND FEATURES

Remote Control box Side-Mount Control Type (optional equipment)

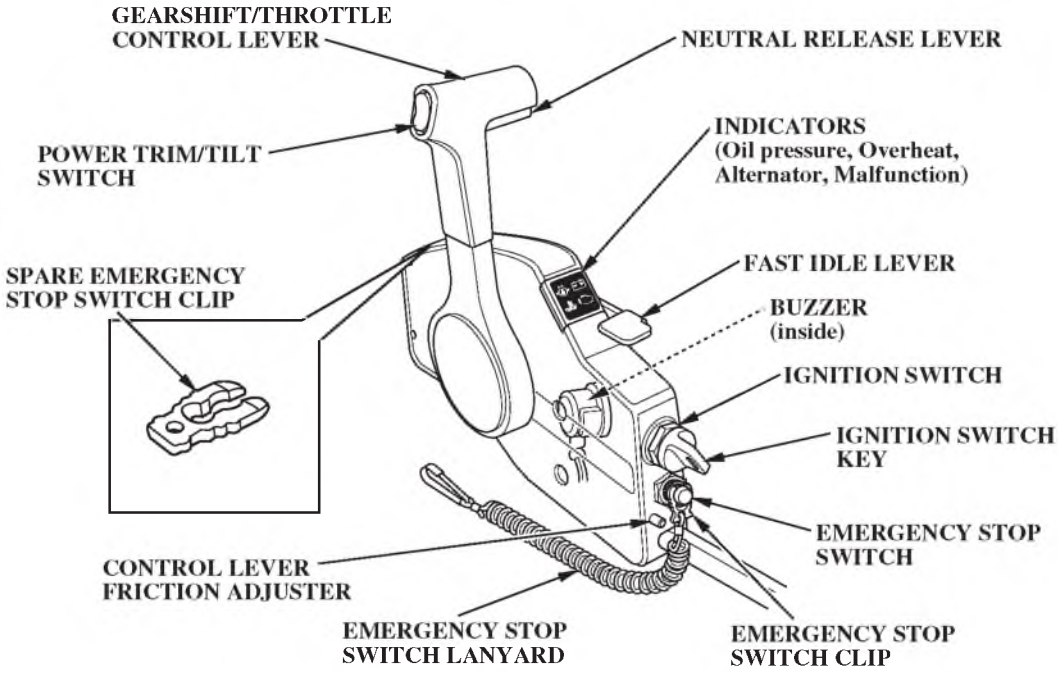

CONTROLS AND FEATURES

**Portable Fuel Tank
(optional equipment)
Fuel Tank Hose Assembly
(standard equipment)**

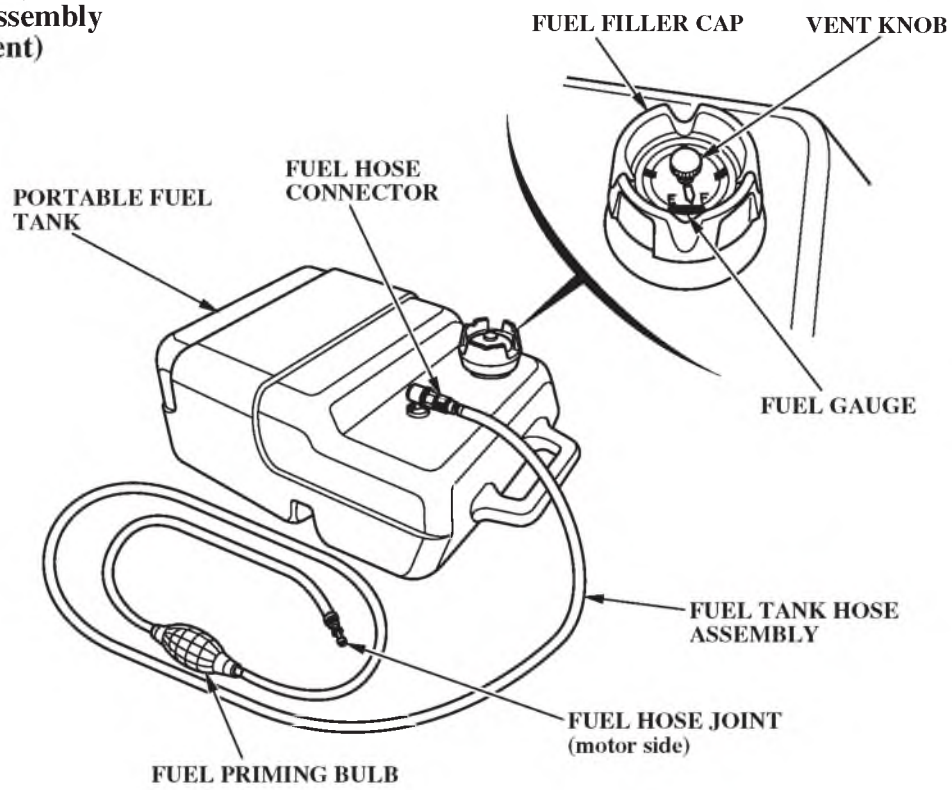

CONTROLS AND FEATURES

Trim Meter
 (optional equipment)



Tachometer
 (optional equipment)



Rudder Meter
 [standard equipment (BFP60A LRTB type)]
 [optional equipment (other LRT and XRT types)]



Trolling Control Switch Panel
 [standard equipment (LRTB type)]
 [optional equipment (other LRT and XRT types)]

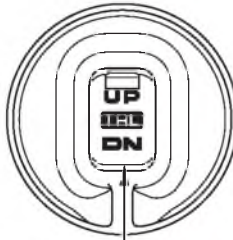

TRL (Trolling) CONTROL SWITCH

Digital Speedometer
 [optional equipment (LRT and XRT types)]

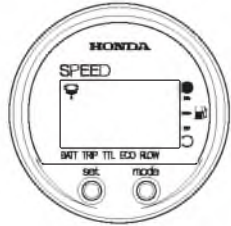

Digital Tachometer
 [optional equipment (LRT and XRT types)]

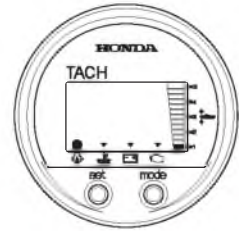

CONTROLS AND FEATURES

CONTROLS

LHT Type (tiller handle)

Ignition Switch

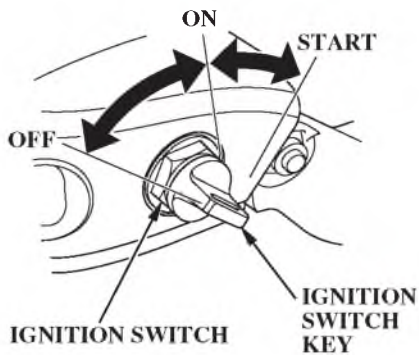

The ignition switch controls the ignition system and the starter motor.

Turning the ignition switch key to the START position operates the starter motor. The key automatically returns to the ON position when released from the START position.

The engine will not start unless the gearshift lever is in the N (neutral) position (p. 50) and the emergency stop switch clip is in the emergency stop switch.

Turning the ignition switch to the OFF position stops the engine.

Emergency Stop Switch Clip and Emergency Stop Switch

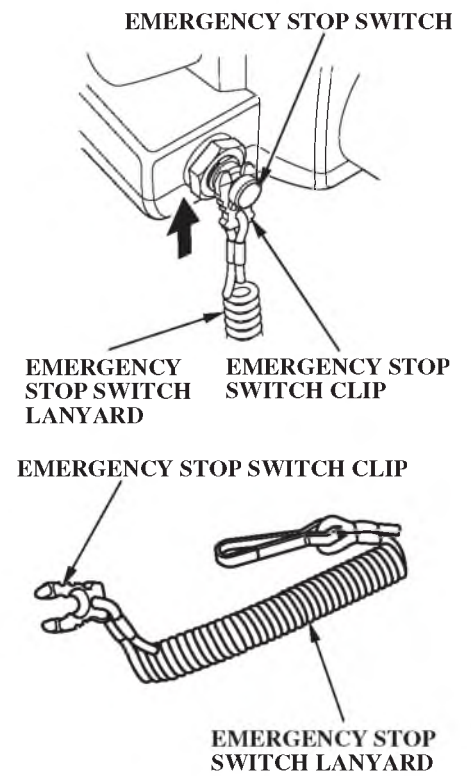

CONTROLS AND FEATURES

The emergency stop switch clip must be inserted in the emergency stop switch in order for the engine to start and run. The emergency stop switch lanyard must be attached securely to the operator or to the operator's PFD (Personal Flotation Device).

When used as described, the emergency stop switch and emergency stop switch lanyard system stops the engine if the operator falls away from the controls.

A spare switch clip is provided in the tool bag (p. 74).



SPARE SWITCH CLIP

Throttle Grip

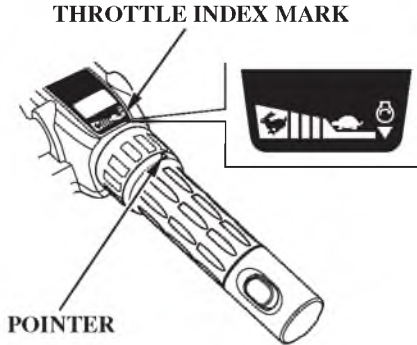
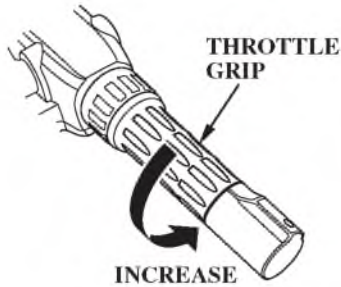

The throttle grip controls engine speed.

An index mark on the tiller arm shows throttle position and is helpful for setting the throttle correctly when starting (p. 62).

CONTROLS AND FEATURES

Throttle Friction Adjuster

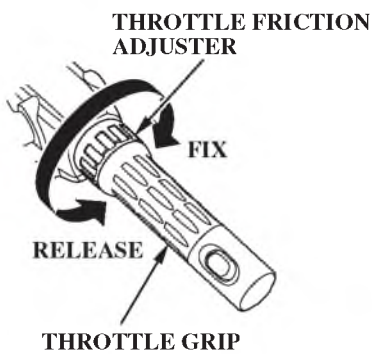

The throttle friction adjuster adjusts resistance to throttle grip rotation.

Turn the adjuster clockwise to increase friction for holding a throttle setting while cruising.

Turn the adjuster counterclockwise to decrease friction for easy throttle grip rotation.

Gearshift Lever

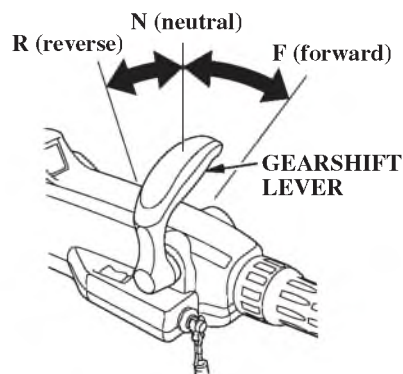

The gearshift lever is used to select F (forward), N (neutral), or R (reverse) gears.

The engine can be started with the gearshift lever in the N (neutral) position only.

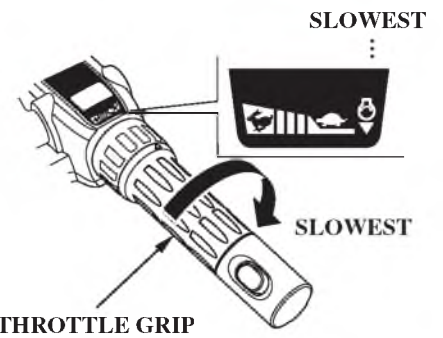

NOTICE

The shift lever will not move unless the throttle grip is in the fully closed position.

CONTROLS AND FEATURES

GEARSHIFT LEVER

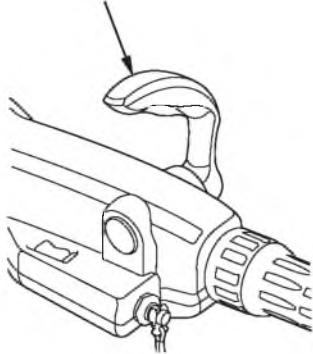

You can chose which side of the tiller handle to have the gearshift lever installed. Consult your authorized Honda outboard motor dealer.

Steering Friction Adjuster

STEERING FRICTION ADJUSTER

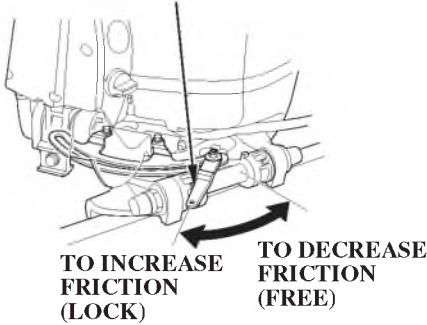

The steering friction adjuster adjusts steering resistance.

Less friction allows the outboard motor to turn more easily. More friction helps to hold a steady course while cruising or to prevent the outboard motor from swinging while trailering the boat.

CONTROLS AND FEATURES

LRT and XRT Types (remote control)

For panel-mount or top-mount remote control information, refer to the instructions provided with the remote control equipment.

Side-Mount Control Type (optional equipment)

Ignition Switch

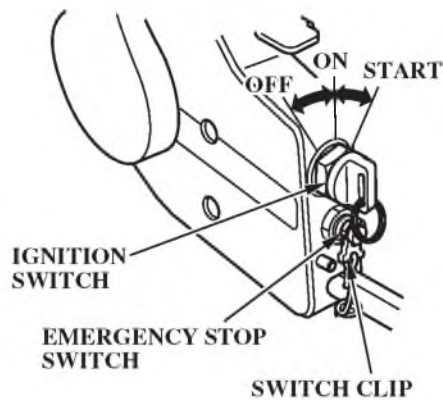

The ignition switch controls the ignition system and the starter motor.

Turning the ignition switch key to the START position operates the starter motor. The key automatically returns to the ON position when released from the START position.

The ignition switch can be used to start the engine only when the control lever is in the N (neutral) position (p. 53) and the emergency stop switch clip is in the emergency stop switch.

Turning the ignition switch to the OFF position stops the engine.

CONTROLS AND FEATURES

Emergency Stop Switch Clip and Emergency Stop Switch

EMERGENCY STOP SWITCH

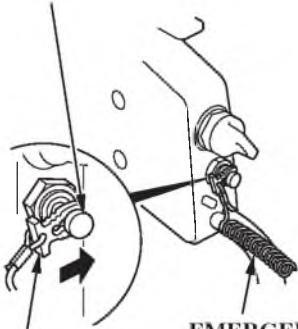

EMERGENCY STOP SWITCH CLIP

EMERGENCY STOP SWITCH LANYARD



EMERGENCY STOP SWITCH CLIP

EMERGENCY STOP SWITCH LANYARD

The emergency stop switch clip must be inserted in the emergency stop switch in order for the engine to start and run. The emergency stop switch lanyard must be attached to the operator's PFD (Personal Flotation Device) or to the operator securely.

When used as described, the emergency stop switch clip and emergency stop switch lanyard system stops the engine if the operator falls away from the controls.

A spare switch clip is stored in a slot in the control housing and is provided in the tool bag (p. 74).

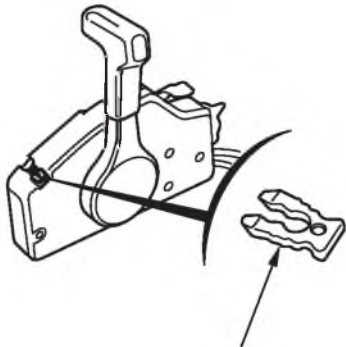

SPARE SWITCH CLIP

CONTROLS AND FEATURES

Gearshift/Throttle Control Lever

GEARSHIFT/THROTTLE CONTROL LEVER

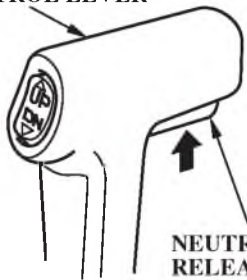

NEUTRAL RELEASE LEVER

The gearshift/throttle control lever controls engine speed and selects F (forward), N (neutral), or R (reverse) gears.

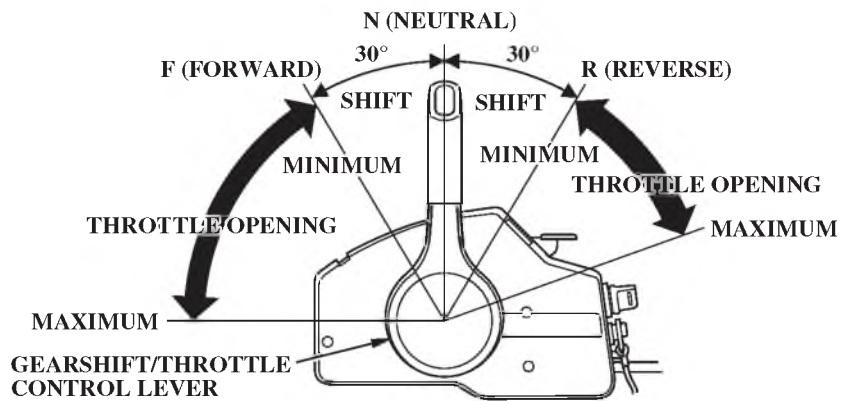

Moving the control lever 30° from N (neutral) selects the gear, and further movement increases engine speed.

The control lever automatically locks itself in the N (neutral) position. To move the lever out of the N (neutral) position, you must squeeze the neutral release lever on the underside of the lever handle.

A friction adjuster near the base of the control lever(s) adjusts the operating resistance of the control lever(s). Refer to p. 63 .

Less friction allows easier control lever movement. More friction helps to hold a steady throttle setting while cruising.

Fast Idle Lever

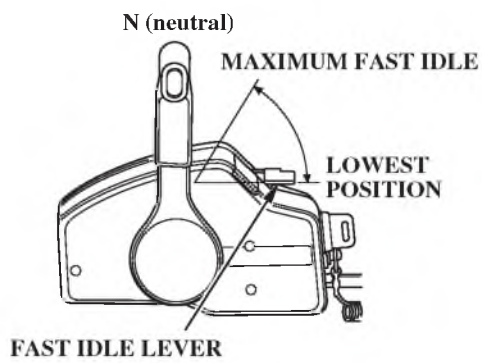

Use the fast idle lever to accelerate engine warm-up after starting the engine. Do not use the fast idle lever when starting the engine.

See page 55 for engine warm-up instructions.

The fast idle lever allows you to increase the idle speed only when the control lever is in the N (neutral) position. Place the fast idle lever in its START (fully lowered) position to cancel the fast idle and return the control lever to normal operation.

CONTROLS AND FEATURES

Common Controls

Power Trim/Tilt Switch (tiller handle/control lever side)

LHT Type

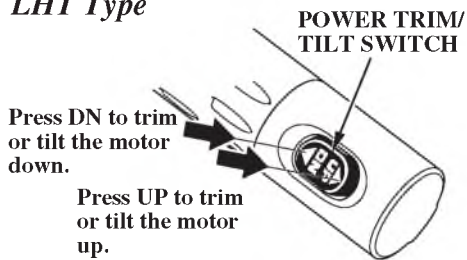

LRT and XRT Types (side-mount control)

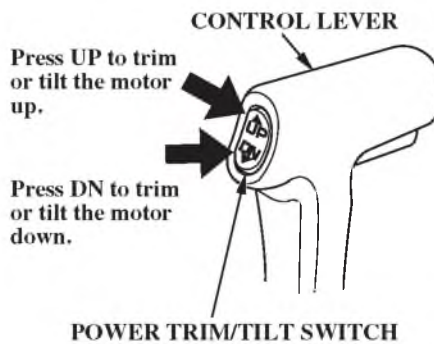

The power trim/tilt switch is located on the tiller handle or on the control lever. It is a rocker switch with UP and DN (down) positions for changing the angle of the outboard motor.

You can use the power trim/tilt switch anytime whether the boat is underway, stopped, or the ignition switch is in the OFF position. It is necessary for the ignition switch to be in the ON position for the trim meter to indicate the motor angle.

Trim the outboard motor to obtain the best performance and stability (p. 65).

Tilt the outboard motor for shallow water operation, beaching, launching, or mooring.

CONTROLS AND FEATURES

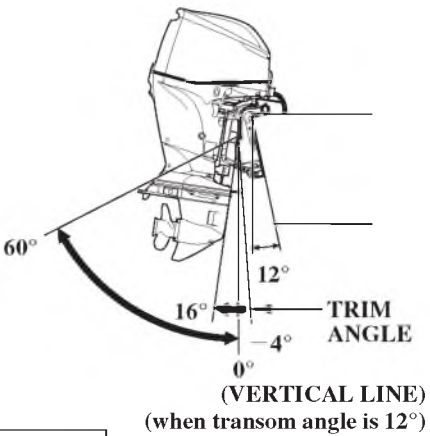

NOTICE

If your outboard motor is equipped with the tilt limit mechanism (optional equipment for remote control type), you can set the tilt angle limit. Contact your dealer for more information.

Power Tilt Switch (engine pan)

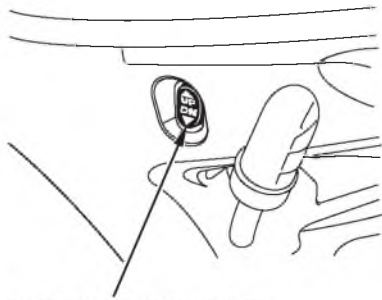

The power tilt switch is located on the engine pan. It is a rocker switch with UP and DN (down) positions for changing the angle of the outboard motor.

The power tilt switch will operate without turning the ignition switch ON.

This switch is used with the engine stopped to raise the outboard motor for mooring, trailering, or maintenance.

NOTICE

The power trim/tilt switch located on the outboard (engine pan) is not limited by the tilt limit mechanism (optional equipment for remote control types) and will provide full range of movement.

CONTROLS AND FEATURES

Manual Relief Valve

MANUAL RELIEF VALVE

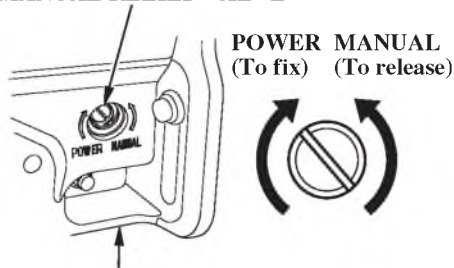

RIGHT STERN BRACKET

The outboard motor can be tilted manually after opening the manual relief valve. This allows the outboard motor to be tilted up or down when no battery is connected.

Check that nobody is under the outboard motor before opening the manual relief valve. If the manual relief valve is loosened (turned counterclockwise) when the outboard motor is tilted up, the outboard motor will suddenly tilt down.

TRL (Trolling) Control Switch [standard equipment (LHTC type)]

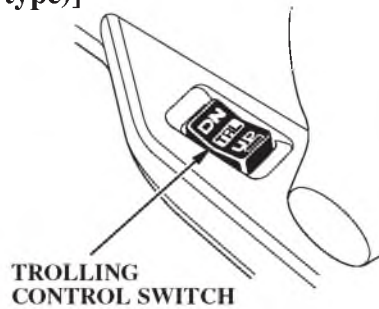

[standard equipment (LRTB type)]
[optional equipment (except LHTC and LRTB types)]

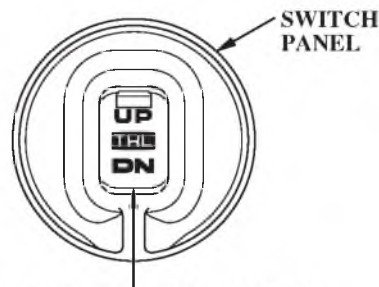

TROLLING CONTROL SWITCH

The Trolling Control Switch is a rocker switch with UP and DN (down) positions to adjust the trolling speed up or down in 50 RPM increments within the range of 750 to 1,000 RPM.

If you press and hold the TRL switch while cruising with the throttle closed, the mode changes to trolling mode (p. 67).

CONTROLS AND FEATURES

Tilt Lock Lever

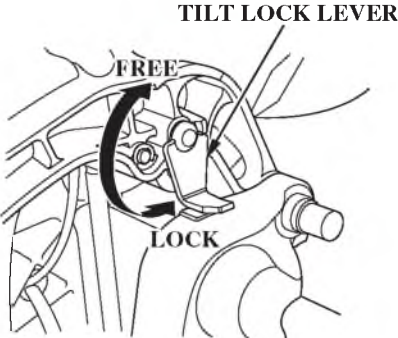

The tilt lock lever is used to support the outboard motor in the fully-raised position.

When the boat is to be moored for a long time, tilt the outboard motor up as far as it will go. Then move the tilt lock lever to the LOCK position, and gently lower the outboard motor until the lever contacts the stern bracket.

Engine Cover Latches

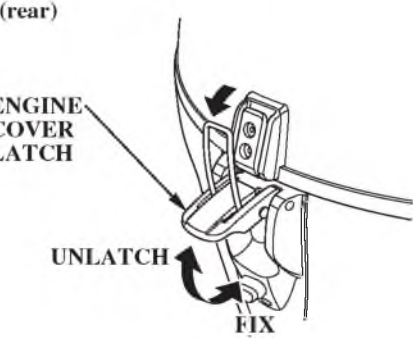
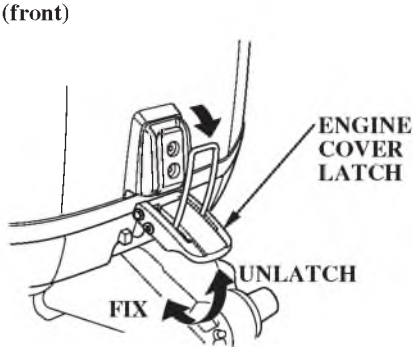

The engine cover latches fasten the engine cover to the outboard motor.

CONTROLS AND FEATURES

Trim Tab

BF60A models:

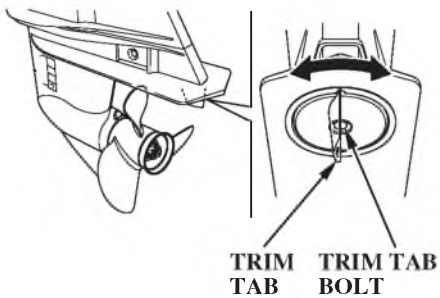

BFP60A models:

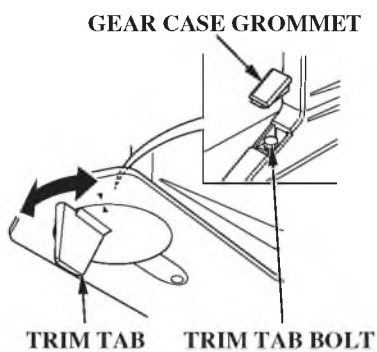

The trim tab compensates for “torque steer,” which is a reaction of the outboard motor to propeller rotation.

If uncompensated, torque steer would make the outboard motor tend to turn to one side.

When the trim tab is correctly adjusted (p. 77), steering effort is equal in either direction.

INSTRUMENTS

**Trim Meter
(optional equipment)**



TRIM METER

The trim meter indicates the relative trim angle of the outboard motor.

Refer to the trim meter when using the power trim/tilt switch to achieve the best performance from the boat.

**Tachometer
(optional equipment)**



TACHOMETER

The tachometer shows engine speed in revolutions per minute.

Refer to the tachometer when using the throttle and power trim/tilt controls to achieve the best performance from the boat.

**Digital Tachometer
[optional equipment (LRT and XRT types)]**

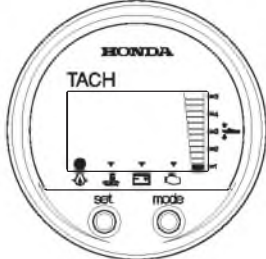

Digital Tachometer includes the following functions.

- Tachometer
- Hour Meter
- Trim Meter
- Oil Pressure Indicator
- Overheat Indicator
- ACG Indicator
- Malfunction Indicator

Refer to the Operation Guide included with the Digital Tachometer for operation information.

CONTROLS AND FEATURES

Digital Speedometer [optional equipment (LRT and XRT types)]

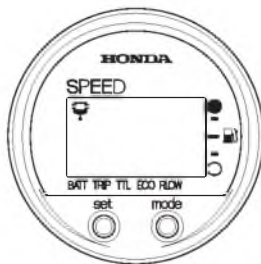

Digital Speedometer includes the following functions.

- Speedometer
- Fuel Level Meter
- Voltmeter
- Tripmeter
- Fuel Integration Meter
- Fuel Economy Meter
- Fuel Flow Meter

Refer to the Operation Guide included with the Digital Speedometer for operation information.

Rudder Meter [standard equipment (BFP60A LRTB type)] [optional equipment (other LRT and XRT types)]



The rudder meter shows the boat's travelling direction in accordance with the rudder angle.

Fuel Gauge (optional equipment)

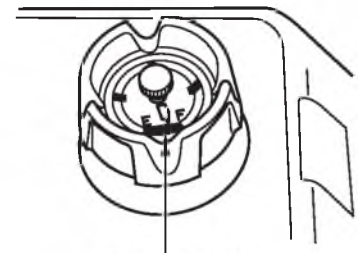

FUEL GAUGE

A fuel gauge is built into the cap of the portable fuel tank (optional equipment).

CONTROLS AND FEATURES

INDICATORS

The indicator lights come on and the buzzer sounds when you turn the ignition switch ON, allowing you to see that they are working. If an indicator does not light during this test, it cannot alert you if that system develops a problem. Have your Honda Marine dealer check for burned-out bulbs or other problems. Under normal conditions, the following occur when the ignition switch is turned ON:

1. The ACG, Malfunction, Oil Pressure, and Overheat indicators light.
2. The buzzer will beep twice.
3. The Malfunction, Oil Pressure, and Overheat indicators will go out after the second beep.
4. The ACG indicator will go out after the engine starts.
5. The Oil Pressure indicator will light again after the engine starts and will stay lit to indicate the oil pressure is normal.

Alternator (ACG) Indicator

LHT Type

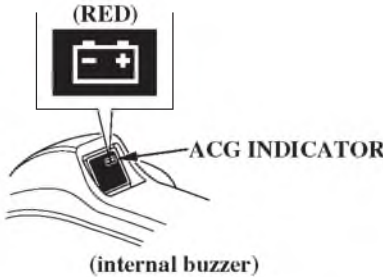

LRT and XRT Types (side-mount control)

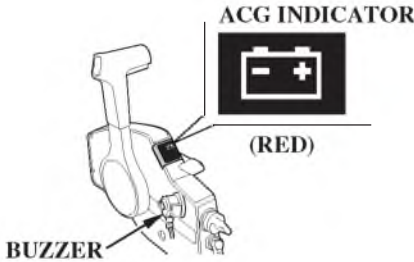

The ACG indicator turns on and the buzzer sounds in one-second intervals when the charging system is faulty.

Malfunction Indicator

LHT Type

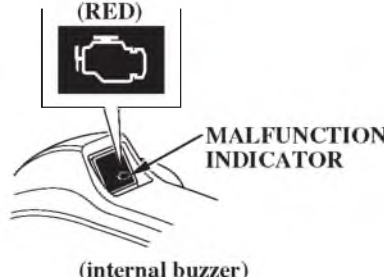

LRT and XRT Types (side-mount control)

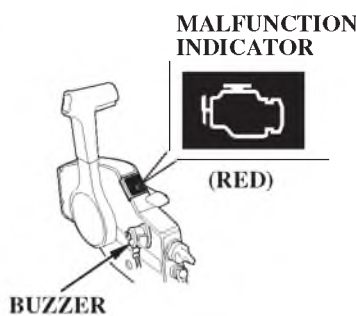

CONTROLS AND FEATURES

When the engine control system detects an engine control system malfunction, the malfunction indicator turns on and the buzzer sounds at one-second intervals.

Oil Pressure Indicator

LHT Type

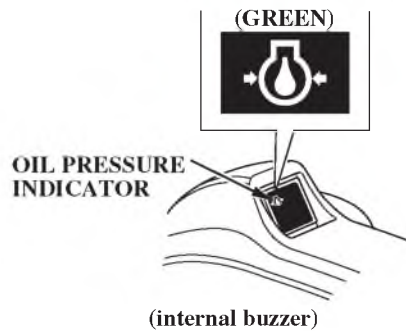

LRT and XRT Types

(side-mount control)

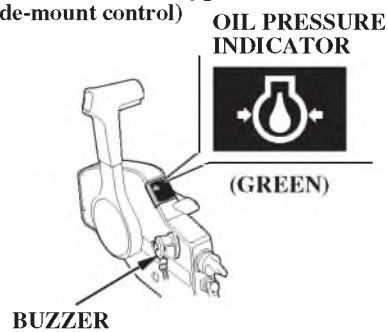

When the oil pressure indicator is lit, oil pressure is OK.

If oil pressure becomes low, the indicator will go off, and the engine protection system will limit engine speed. Refer to *TAKING CARE OF UNEXPECTED PROBLEMS*, on p. 112.

All models are equipped with a buzzer that sounds continuously when the oil pressure indicator goes off.

Low oil pressure indicates that the engine oil level is low or that there is a problem with the engine lubrication system.

CONTROLS AND FEATURES

Overheat Indicator

LHT Type

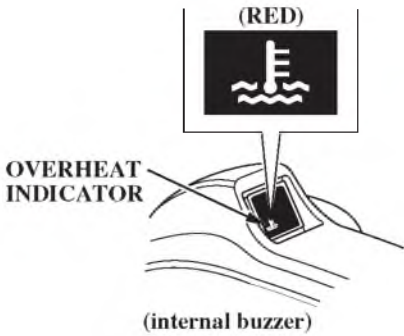

LRT and XRT Types (side-mount control)

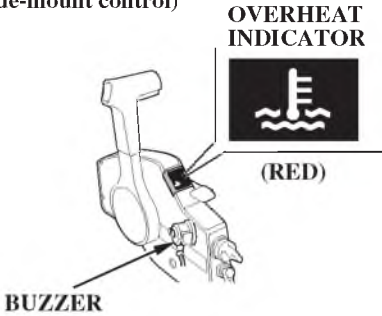

When the alert triggers, the overheat indicator comes on and the buzzer sounds a steady tone as the engine speed is reduced to 1,800 rpm. If the condition persists for another 20 seconds, the engine shuts off. Refer to *TAKING CARE OF UNEXPECTED PROBLEMS*, on p. 113 .

All models are equipped with a buzzer that sounds continuously when the red light comes on.

Engine overheating may be the result of clogged water intakes.

Cooling System Indicator

COOLING SYSTEM INDICATOR

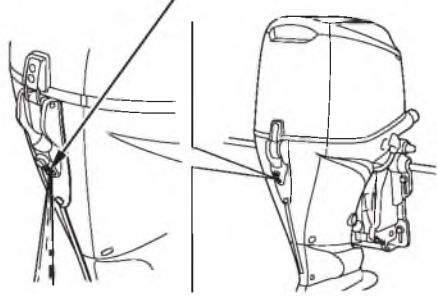

Water should flow from the cooling system indicator while the engine is running. This shows that water is circulating through the cooling system.

If water stops flowing while the engine is running, it indicates a cooling system problem, such as clogged water intakes, which will cause engine overheating. Refer to *TAKING CARE OF UNEXPECTED PROBLEMS*, on p. 114 .

CONTROLS AND FEATURES

The cooling system indicator discharge port can also become plugged.

OTHER FEATURES

Overrev Limiter

The engine is equipped with an overrev limiter to prevent the possibility of mechanical damage from excessive engine speed.

The overrev limiter may be activated during operation, limiting engine speed, if the outboard motor is trimmed or tilted up excessively, or when propeller ventilation occurs during a sharp turn.

If the overrev limiter is activated, check the trim angle of the outboard motor.

Check to see if the correct propeller is installed.

Portable Fuel Tank (optional equipment)

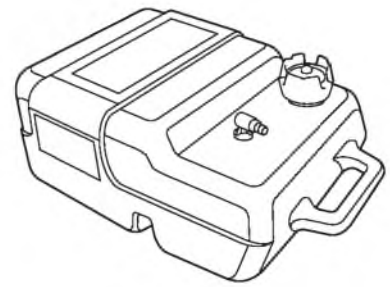

The portable fuel tank has a capacity of 6.6 US gal (25L) and has a fuel gauge built into the cap.

CONTROLS AND FEATURES

**Fuel Filler Cap Vent Knob
(optional equipment)**

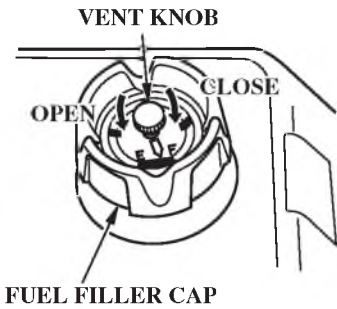

The cap is provided with a vent knob to seal the portable fuel tank for carrying it to and from the boat. Open the vent knob 2 or 3 turns before starting the engine.

Fuel Priming Bulb

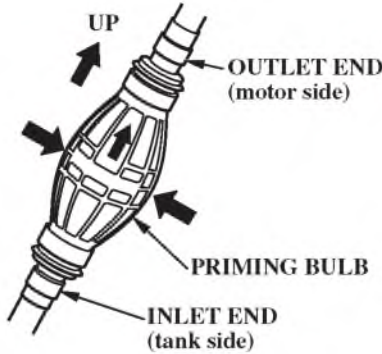

A priming bulb is built into the fuel hose that connects the fuel tank to the outboard motor.

Before starting the engine, hold the priming bulb up in the direction of the arrow; then squeeze the priming bulb until it feels firm. This will ensure that fuel is supplied to the engine (p. 49).

NMEA Interface Coupler

NMEA2000® based information on engine speed, fuel consumption, and various warnings can be read by connecting to the motor with the interface cable (optional). Contact your dealer for more information.

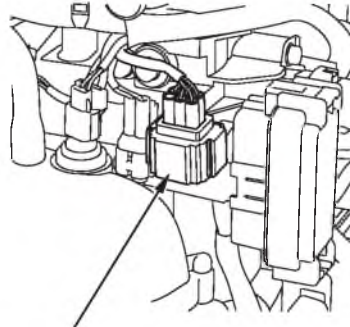

NMEA INTERFACE COUPLER

CONTROLS AND FEATURES

Anodes

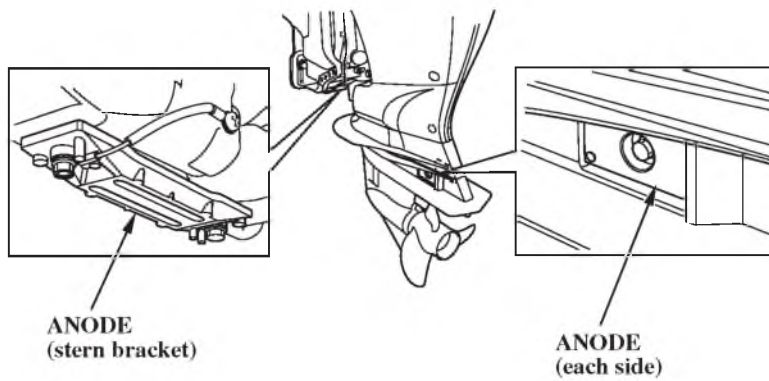

The anodes are made of a sacrificial material that helps to protect the outboard motor from corrosion.

There are two anodes on the gear case, one on the stern bracket and four small anodes in the water passages of the engine block.

ARE YOU READY TO GET UNDERWAY?

Your safety is your responsibility. A little time spent in preparation will significantly reduce your risk of injury.

Knowledge

Read and understand this manual. Know what the controls do and how to operate them.

Familiarize yourself with the outboard motor and its operation before you get underway. Know what to do in case of an emergency.

Familiarize yourself with all laws and regulations relating to boating and the use of outboard motors.

Safety

Always wear a PFD (Personal Flotation Device) while on the boat.

Attach the emergency stop switch clip securely to the operator or to the operator's PFD (Personal Flotation Device).

IS YOUR OUTBOARD MOTOR READY TO GO?

For your safety, and to maximize the service life of your equipment, it is very important to take a few moments before you operate the outboard motor to check its condition. Be sure to take care of any problem you find, or have your authorized Honda Marine dealer correct it, before you operate the outboard motor.

BEFORE OPERATION

WARNING

Improperly maintaining this outboard motor or failing to correct a problem before operation can cause a malfunction in which you could be seriously hurt or killed.

Always perform a pre-operation inspection before each operation, and correct any problem.

Before beginning your pre-operation checks, be sure the ignition switch is in the OFF position.

BEFORE OPERATION

Safety Inspection

- Look around the outboard motor for signs of oil or gasoline leaks.
- If you are using the portable fuel tank (optional equipment), make sure it is in good condition and properly secured in the boat (p. 47).
- Check that the fuel hose is undamaged and properly connected.
- Wipe up any spills before starting the engine.
- Check the stern bracket to be sure the outboard motor is securely installed.
- Check that all controls are operating properly.
- Replace any damaged parts.

- Check that all fasteners are in place and securely tightened.
- Check the emergency stop switch for proper operation (p. 22 , 27). Start the engine. Make sure the engine stops by pulling the emergency stop switch clip from the emergency stop switch (p. 59).

Maintenance Inspection

- Check the engine oil level (p. 80). Running the engine with a low oil level can cause engine damage.
- Check to be sure the propeller is undamaged and the castle nut is secured with the cotter pin (p. 94).
- Check that the anodes are securely attached to the stern bracket and the gear case (p. 93) and are not excessively worn. The anodes help protect the outboard motor from corrosion.

- Make sure a tool kit and the emergency starter rope are onboard (p. 74). Replace any missing items.
- Check the fuel level in the fuel tank (p. 87).
- Check that the battery fluid is between the upper and lower levels, and the battery leads are connected securely.
- Check the fuel filter for water contamination (p. 89).

BEFORE OPERATION

Tiller Handle Height/Angle Adjustment (LHT type)

The tiller handle height and angle can be adjusted to three positions by changing the installation direction of the height adjustment block. Select a suitable height and angle for the operator and secure the block.

1. Raise the tiller handle and remove the 8 × 28 mm flange bolt and the height adjustment block.
2. Pull down the tiller handle. Determine the height adjustment block installation direction and secure the block with the 8 × 28 mm flange bolt.

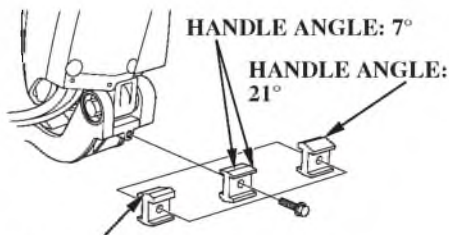

HANDLE ANGLE: 13°

Install the height adjustment block so that the selected angle of the tiller handle is in this position.

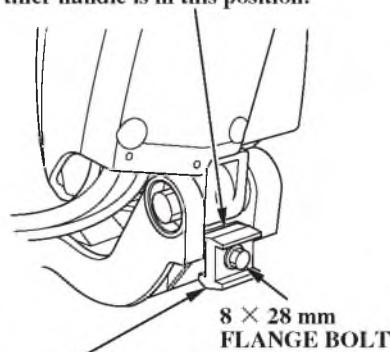

HEIGHT ADJUSTMENT
BLOCK

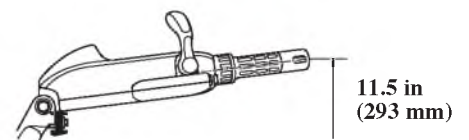
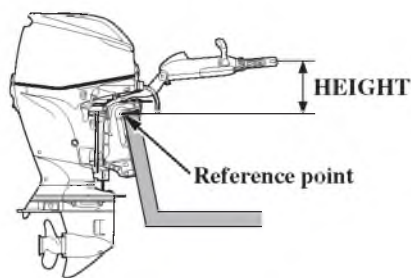

HANDLE ANGLE: 7°

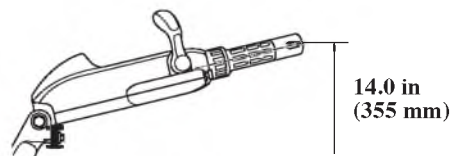

HANDLE ANGLE: 13°

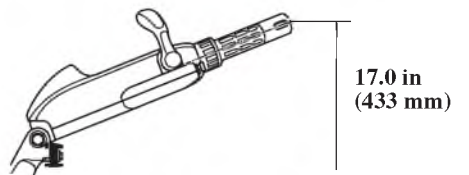

HANDLE ANGLE: 21°

OPERATION

SAFE OPERATING PRECAUTIONS

To safely realize the full potential of this outboard motor, you need a complete understanding of its operation and a certain amount of practice with its controls.

Before operating the outboard motor for the first time, please review the *IMPORTANT SAFETY INFORMATION* on page 7 and the chapter titled *BEFORE OPERATION*.

For your safety, do not start or run the engine in a confined or partly enclosed area. Your engine's exhaust contains poisonous carbon monoxide, a colorless, odorless gas that can collect rapidly. Breathing carbon monoxide can cause loss of consciousness and may lead to death.

BREAK-IN PROCEDURE

Break-in period: 10 hours

Proper break-in operation allows the moving parts to wear in smoothly for best performance and long service life.

First 15 minutes:

Run the engine at trolling speed. Use the minimum throttle opening necessary to operate the boat at a safe trolling speed.

Next 45 minutes:

Run the engine up to a maximum of 2,000 to 3,000 rpm, which is about 10% to 30% of maximum throttle opening.

Next 60 minutes:

Run the engine up to a maximum of 4,000 to 5,000 rpm, which is about 50% to 80% of maximum throttle opening.

Short full-throttle bursts are OK, but do not operate the engine continuously at full throttle.

For boats that plane easily, bring the boat up on plane, and then reduce the throttle opening to the recommended rpm range.

Next 8 hours:

Do not run the engine at full throttle for more than 5 minutes at a time.

PORTABLE FUEL TANK (optional equipment)

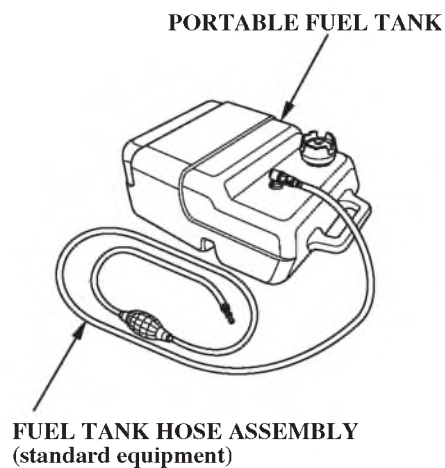

Place the portable fuel tank in a well-ventilated location, away from direct sunlight, to reduce the possibility of a gasoline vapor explosion.

To ensure that the outboard motor will be able to draw fuel from the tank, place the tank within 6 feet of the outboard motor and not more than 3 feet below the fuel connector on the outboard motor.

Secure the portable fuel tank in the boat so that it won't move around and become damaged.

Before use, open the fuel tank vent by turning the vent knob at least 2 or 3 turns counterclockwise.

⚠ WARNING

Gasoline is highly flammable and explosive.

You can be burned or seriously injured when handling fuel.

- Stop the engine and keep heat, sparks, and flame away.
- Handle fuel only outdoors.
- Wipe up spills immediately.

OPERATION

FUEL HOSE CONNECTIONS

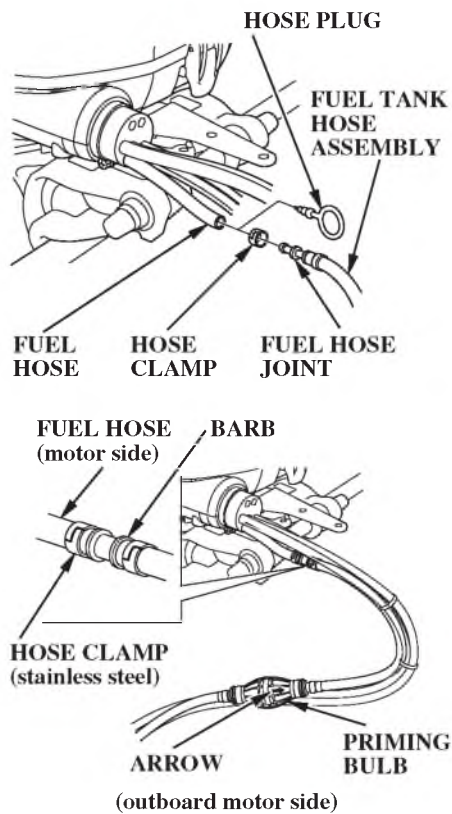

1. Remove the hose plug from the motor side fuel hose. Insert the fuel hose joint into the motor side fuel hose and secure it with the hose clamp. Make sure the arrow mark on the priming bulb points toward the motor side.
 - Store the hose plug in a secure place.

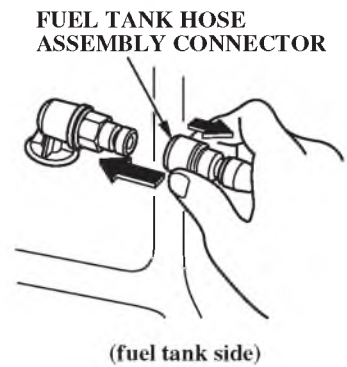

2. Connect the fuel tank hose assembly connector to the tank, as shown. Be sure the connector snaps securely into place.

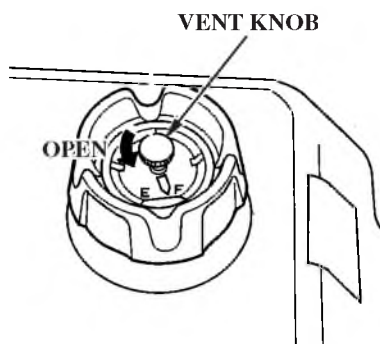

3. Open the fuel filler cap vent knob 2 to 3 turns.

FUEL PRIMING

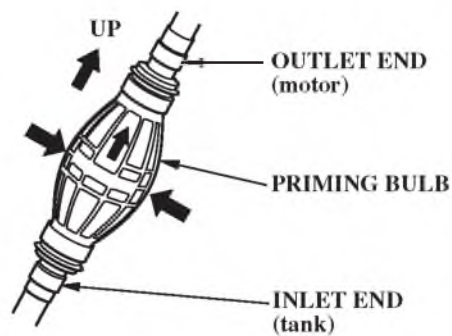

Hold the priming bulb up in the direction of the arrow; then squeeze the priming bulb several times until it feels firm, indicating that fuel has reached the engine.

Check to be sure there are no fuel leaks before starting the engine.

Do not touch the priming bulb with the engine running or when tilting up the outboard motor. The vapor separator could overflow.

⚠ WARNING

Gasoline is highly flammable and explosive.

You can be burned or seriously injured when handling fuel.

- Stop the engine and keep heat, sparks, and flame away.
- Handle fuel only outdoors.
- Wipe up spills immediately.

OPERATION

STARTING THE ENGINE

Control Side-Mount Control Type Page 53

LHT Type (tiller handle)

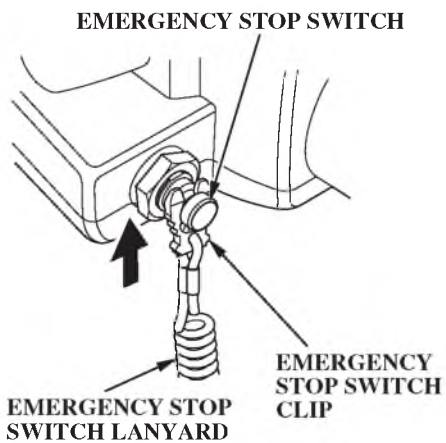

1. Put the emergency stop switch clip in the emergency stop switch, and attach the emergency stop switch lanyard securely to the operator or to the operator's PFD (Personal Flotation Device).

The engine will not start or run unless the emergency stop switch clip is in the emergency stop switch.

The emergency stop switch clip and emergency stop switch lanyard system is a safety device that will stop the engine if you fall away from the controls while operating the boat.

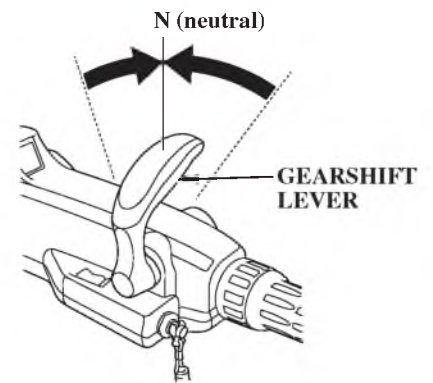

Always attach the emergency stop switch lanyard securely to the operator or to the operator's PFD before starting the engine.

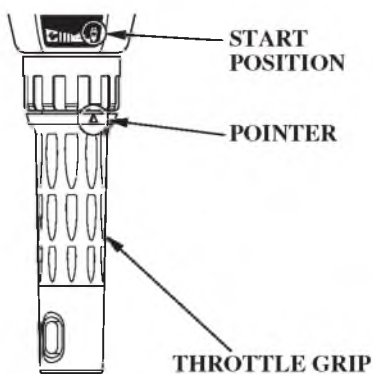

2. Check the position of the gearshift lever. It must be in the N (neutral) position for starting.

The engine will not start if the gearshift lever is in the F (forward) or R (reverse) position.



3. Align the engine start symbol “” on the tiller handle with the pointer “” on the throttle grip.
4. Turn the ignition switch key to the ON position; the buzzer will sound two times.

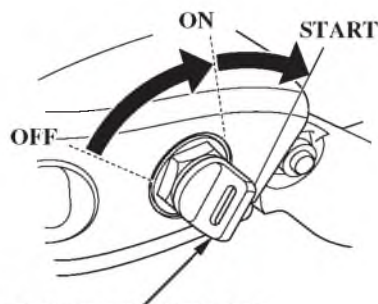

IGNITION SWITCH KEY

5. Turn the ignition switch key to the START position and hold it there until the engine starts. When the engine starts, release the key, allowing it to return to the ON position.

If the engine fails to start within 5 seconds, release the key and wait at least 10 seconds before operating the starter again.

NOTICE

- Using the electric starter for more than 5 seconds at a time will overheat the starter motor and can damage it.
- Turning the ignition switch key to the START position while the engine is running can damage the starter motor and flywheel.

Also, as the engine warms up, the throttle grip can be turned to the SLOW position without stalling.

OPERATION

6. Before getting underway, allow the engine to warm-up sufficiently to ensure good performance.

Above 41°F (5°C), warm-up the engine for at least 3 minutes.

Below 41°F (5°C), warm-up the engine for at least 5 minutes at 2,000 rpm.

NOTICE

- *If the engine is not properly warmed up before raising the engine speed, the buzzer and overheat indicator may activate and the engine speed will be automatically reduced.*
- *The cooling system may freeze in areas where the temperature reaches 32°F (0°C) or below. Cruising at high speed without warming the engine up may cause engine damage.*

During the warm-up period, check the oil pressure indicator (p. 38), overheat indicator (p. 39), and cooling system indicator (p. 39).

If the indicators show any abnormal condition, immediately stop the engine and determine the cause of the problem. Refer to **TAKING CARE OF UNEXPECTED PROBLEMS** on p. 104 – 108.

LRT and XRT Types (remote control)

Side-Mount Control Type (optional equipment)

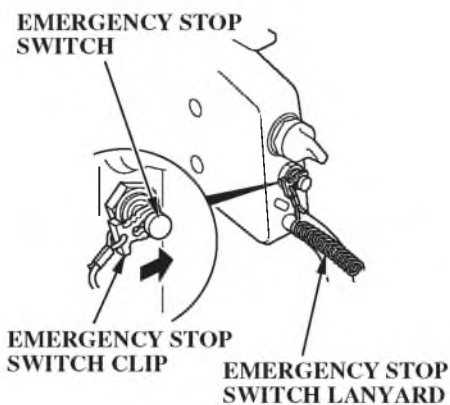

1. Put the emergency stop switch clip in the emergency stop switch, and secure it to the operator or to the operator's PFD (Personal Flotation Device).

The engine will not start or run unless the emergency stop switch clip is in the emergency stop switch.

The emergency stop switch clip and emergency stop switch lanyard system is a safety device that will stop the engine if you fall away from the controls while operating the boat.

Always attach the emergency stop switch lanyard securely to the operator or to the operator's PFD before starting the engine.

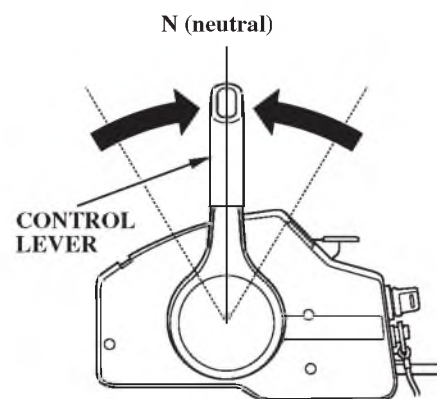

2. Set the control lever in the N (neutral) position.

The engine will not start if the F (forward) or R (reverse) gears are engaged.

OPERATION

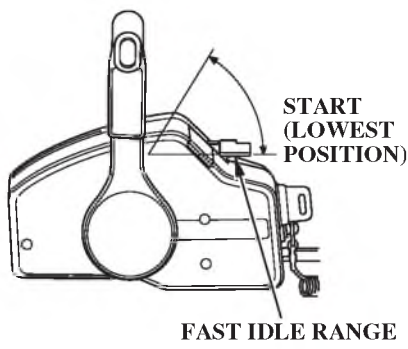

3. Leave the fast idle lever in the START (fully lowered) position.

The fast idle lever cannot be raised unless the control lever is in the N (neutral) position.

The control lever cannot be moved away from the N (neutral) position unless the fast idle lever is lowered.

4. Turn the ignition switch key to the ON position; the buzzer will sound two times.

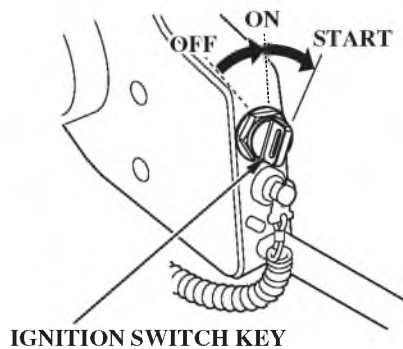

5. Turn the ignition switch key to the START position and hold it there until the engine starts. When the engine starts, release the key, allowing it to return to the ON position.

If the engine fails to start within 5 seconds, release the key and wait at least 10 seconds before operating the starter again.

NOTICE

- Using the electric starter for more than 5 seconds at a time will overheat the starter motor and can damage it.
- Turning the ignition switch key to the START position while the engine is running can damage the starter motor and flywheel.

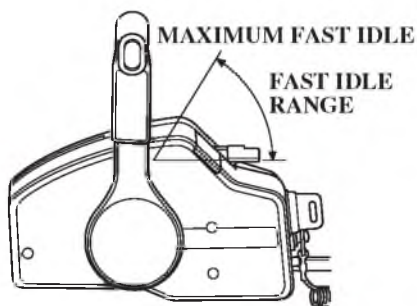

6. Before getting underway, allow the engine to warm-up sufficiently to ensure good performance.

Above 41°F (5°C), warm-up the engine for at least 3 minutes.

Below 41°F (5°C), warm-up the engine for at least 5 minutes at 2,000 rpm. Raise the fast idle lever to achieve approximately 2,000 rpm.

NOTICE

- *If the engine is not properly warmed up before raising the engine speed, the buzzer and overheat indicator may activate and the engine speed will be automatically reduced.*
- *The cooling system may freeze in areas where the temperature reaches 32°F (0°C) or below. Cruising at high speed without warming the engine up may cause engine damage.*

During the warm-up period, check the oil pressure indicator (p. 38), overheat indicator (p. 39), and cooling system indicator (p. 39).

If the indicators show any abnormal condition, immediately stop the engine and determine the cause of the problem. Refer to **TAKING CARE OF UNEXPECTED PROBLEMS** on p. 104 – 108.

7. If the fast idle lever was used to warm-up the engine, gradually lower the lever as the engine warms up.

When the fast idle lever is fully lowered, the control lever can be moved away from the N (neutral) position.

OPERATION

EMERGENCY STARTING

If the battery is discharged or the starter motor is inoperative, you can start the engine manually using the emergency starter rope supplied with the motor.

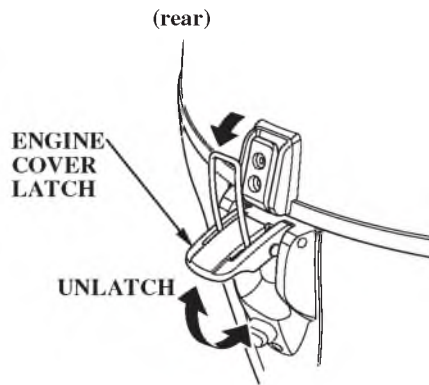
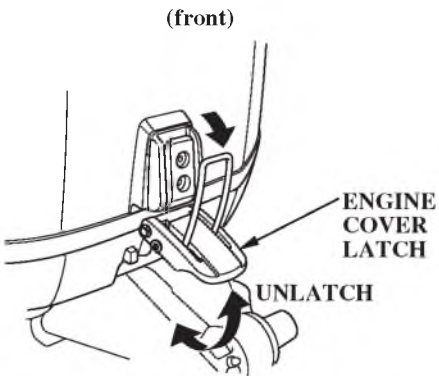

1. Turn the engine switch key to the OFF position.
2. Unlatch and remove the engine cover.

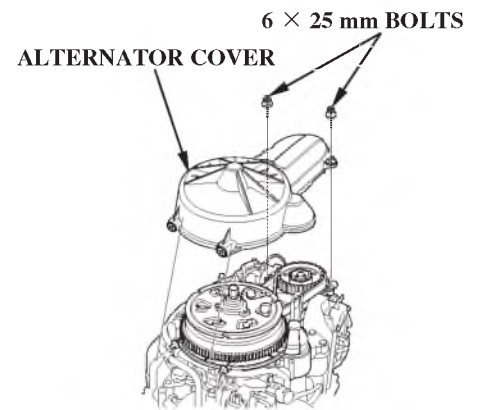

3. Remove the two 6 × 25 mm bolts, and then remove the alternator cover.

NOTE:
Take care not to lose the bolts.

OPERATION

4. Set the controls the same as for normal starting (see pages 50 — 51, 53 — 55).

Turn the ignition switch key to the ON position.

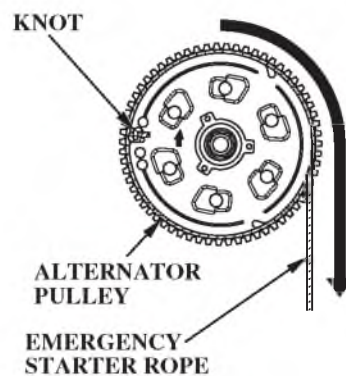

5. Set the alternator pulley so the cutouts are on the right and left sides of the alternator pulley as shown. Hook the knot at the end of the starter rope (accessory) against a cutout in the alternator pulley, and wind the starter rope one and a half turns clockwise along the groove in the alternator pulley.

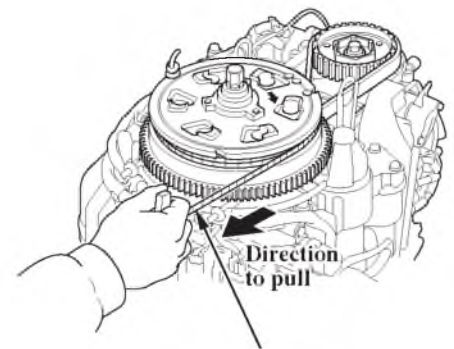

EMERGENCY STARTER ROPE

6. Pull the emergency starter rope slowly until resistance is felt, then pull briskly.

Keep away from moving parts while pulling the rope.

If necessary, rewind the rope and pull again. If the engine does not start after several attempts, refer to *TAKING CARE OF UNEXPECTED PROBLEMS* from p. 104.

OPERATION

7. If the fast idle control(s) was used to start the engine, return the control(s) to the normal operating position as the engine warms up.

During the warm-up period, check the oil pressure indicator (p. 38), overheat indicator (p. 39), and cooling system indicator (p. 39).

8. Leave the alternator cover off, but install the engine cover (p. 79) and lock it in place by latching the engine cover latch.

⚠ WARNING

Exposed moving parts can cause injury.

- Do not operate the outboard motor without the engine cover.
- Use extreme care when installing the engine cover.

9. If it was necessary to remove the emergency stop switch lanyard from you to perform the emergency starting procedure, be sure the lanyard is attached securely to operator before operating the outboard motor.

10. Have your closest authorized Honda Marine dealer check your electrical system and correct the problem so that you can use the electric starter.

STOPPING THE ENGINE

Emergency Engine Stopping

LHT Type (tiller handle)

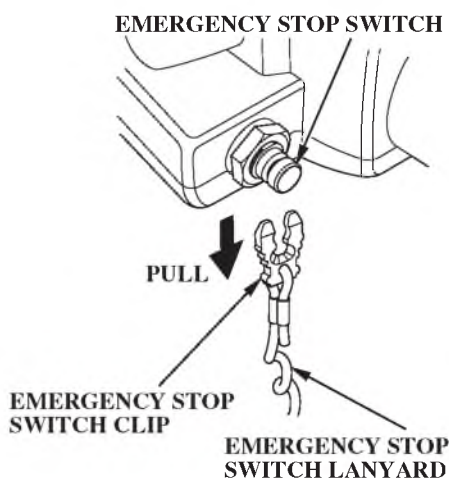

*LRT and XRT Types
(remote control)*

**Side-Mount Control Type
(optional equipment)**

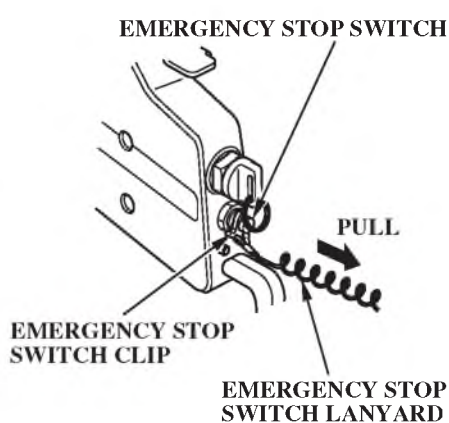

To stop the engine in an emergency, pull the emergency stop switch clip out of the emergency stop switch by pulling the emergency stop switch lanyard.

We suggest that you stop the engine this way occasionally to verify that the emergency stop switch is operating properly.

Turn the ignition switch key to the OFF position after verifying the emergency stop switch operation.

OPERATION

Normal Engine Stopping

LHT Type (tiller handle)

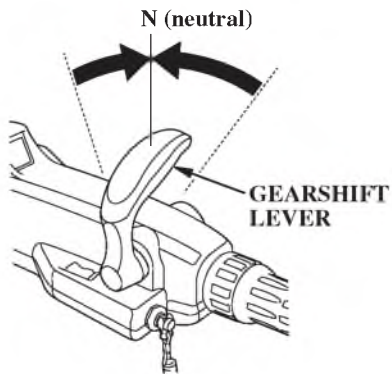
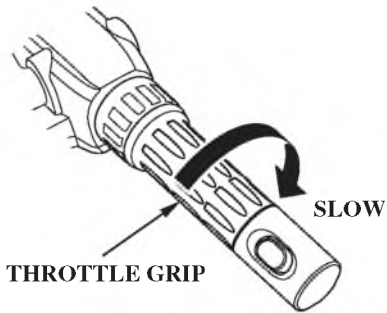

LRT and XRT Types (remote control)

Side-Mount Control Type (optional equipment)

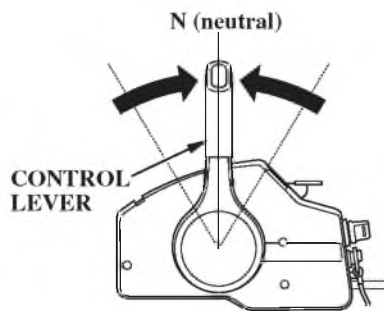

1. Move the throttle grip to the slowest speed and the gearshift lever or control lever to the N (neutral) position.

After cruising at full throttle, cool down the engine by idling for a few minutes before stopping the engine.

LHT Type (tiller handle)

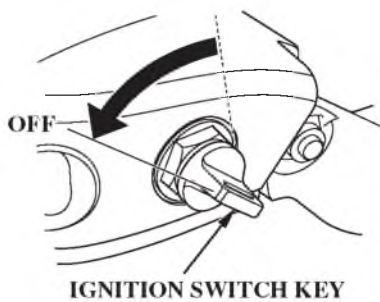

LRT and XRT Types (remote control)

Side-Mount Control Type

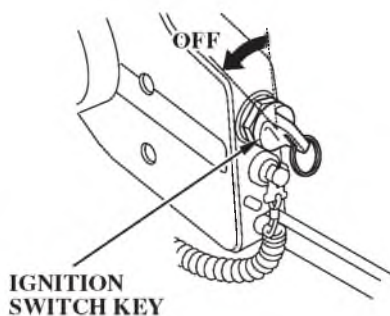

2. Turn the ignition switch key to the OFF position to stop the engine. In the event that the engine does not stop when the ignition switch key is turned to OFF, pull the emergency stop switch clip out of the emergency stop switch by pulling the emergency stop switch lanyard (p. 59).
3. When the boat is not in use, remove and store the ignition switch key and the emergency stop switch clip and lanyard.

OPERATION

GEARSHIFT AND THROTTLE OPERATION

LHT Type (tiller handle)

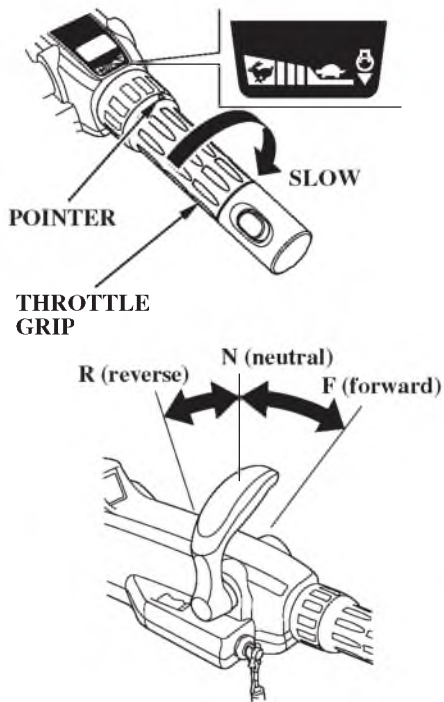

To shift gears, turn the throttle grip to the SLOW position; then move the gearshift lever to select F (forward), N (neutral), or R (reverse) gears.

The engine can be started with the gearshift lever in the N (neutral) position only.

The throttle grip can be turned to the FAST position only when the gearshift lever is in the F (forward) position.

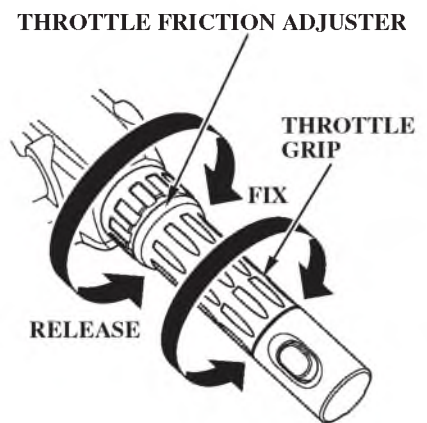

Use the throttle friction adjuster to help hold a constant throttle setting while cruising.

Turn the adjuster clockwise to increase throttle grip friction for holding a constant speed.

Turn the adjuster counterclockwise to decrease friction for easy grip rotation.

***LRT and XRT Types
(remote control)***

Side-Mount Control Type

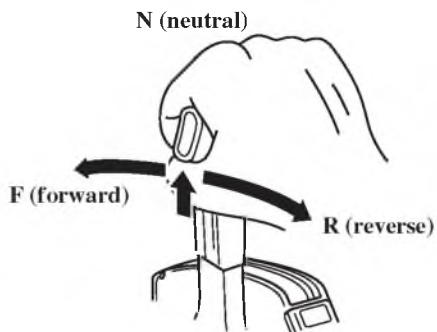
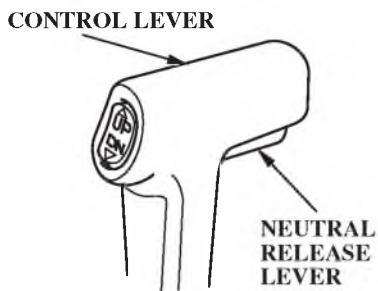

To shift gears, move the control lever to select the F (forward), N (neutral), or R (reverse) gear.

The control lever cannot be moved from the N (neutral) position unless the neutral release lever is squeezed.

Moving the control lever beyond the gear selection range increases engine speed.

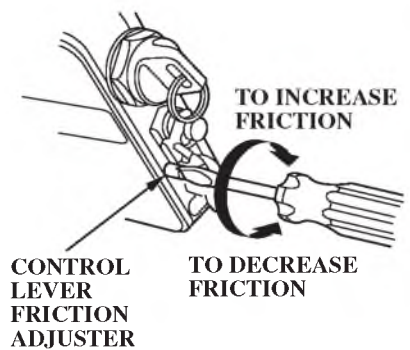

Adjust the control lever friction adjuster so the control lever will hold a constant throttle setting while cruising.

OPERATION

STEERING

LHT Type (tiller handle)

RIGHT TURN

LEFT TURN



Move the tiller handle to the left.



Move the tiller handle to the right.

Steer by moving the tiller handle opposite the direction you want the boat to turn.

Steering Friction Adjuster

FRICION
PLATE

STEERING FRICTION
ADJUSTER

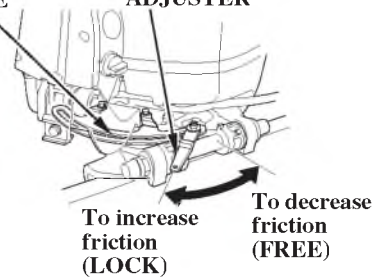

Use the steering friction adjuster to help hold a steady course while cruising.

Move the adjuster to the LOCK direction to increase steering friction for holding a steady course.

Move the adjuster to the FREE direction to decrease friction for easy turning.

NOTICE

Do not apply grease or oil on the friction plate. Grease or oil will reduce the friction of the adjuster.

LRT and XRT Types (remote control)

Steer the boat in the same manner as an automobile.

CRUISING

Engine Speed

For best fuel economy, limit the throttle opening to 80%. Use the throttle friction control (p. 62 — 63) to help you hold a steady speed.

For rough water conditions or large waves, slow down to prevent the propeller from rising out of the water.

The engine is equipped with an overrev limiter to prevent the possibility of mechanical damage from excessive engine speed.

If, for example, the outboard motor is tilted excessively or propeller ventilation occurs during a sharp turn, the engine may overrev, activating the overrev limiter.

If engine speed becomes unstable at high speed due to activation of the overrev limiter, reduce speed and check the trim angle of the outboard motor.

Trim

Use the power trim/tilt switch to trim the outboard motor for the best performance and stability.

You can use the power trim/tilt switch at any time, whether the boat is underway or stopped.

Press the UP or DN (down) side of the switch to adjust the angle of the outboard motor.

Refer to the trim meter (p. 35) for an indication of whether the motor is trimmed high or low.

It is necessary to trim the angle of the outboard motor to compensate for changes in boat load, weight distribution, water conditions, or propeller selection.

Under normal conditions, the boat will perform best when the antiventilation plate is level with the water surface.

When cruising into a high wind, trim the outboard motor down slightly to level the boat and improve stability. With a tail wind, trim the outboard motor up slightly.

NOTICE

Excessive trim/tilt angle during operation can cause propeller ventilation, overheating, and water pump damage. This type of damage is not covered by the Distributor's Limited Warranty (p. 129).

OPERATION

LHT Type (tiller handle)

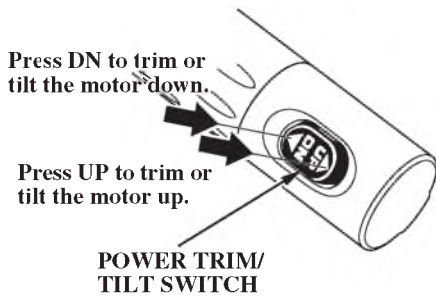

LRT and XRT Types (remote control)

Side-Mount Control Type

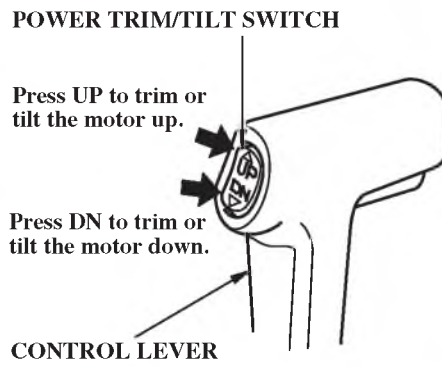

MOTOR TRIMMED TOO LOW



MOTOR TRIMMED TOO HIGH



MOTOR TRIMMED CORRECTLY



BOW TOO LOW DUE TO

1. LOAD IN THE FRONT
2. MOTOR TRIMMED TOO LOW



BOW TOO HIGH DUE TO

1. LOAD IN THE REAR
2. MOTOR TRIMMED TOO HIGH

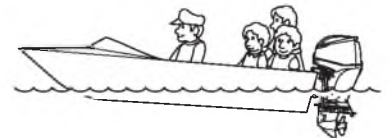

**Trolling Speed Control
[standard equipment (LHTC
type)]**

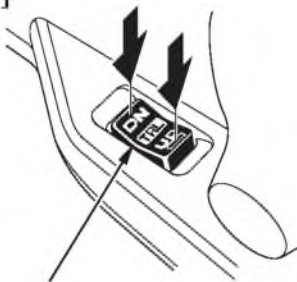

TRL (Trolling) CONTROL SWITCH

**[standard equipment (LRTB
type)]
[optional equipment (except
LHTC and LRTB types)]**

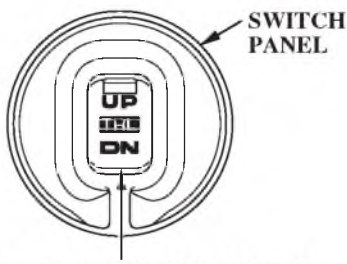

TRL (Trolling) CONTROL SWITCH

DN: Reduce engine speed
UP: Increase engine speed

Place the outboard in-gear with the throttle control in the fully closed (idle) position. Press and hold the UP or DN side of the TRL switch to activate the Trolling Speed Control. The buzzer will make one long sound indicating activation. The initial trolling speed is set at 850 RPM.

The engine speed can be adjusted in 50 RPM increments. A short sound of the buzzer occurs each time the engine speed is adjusted. In Trolling Speed Control mode, the engine speed can be adjusted between 750 and 1,000 RPM. Continuing to press the switch when at either of these limits will result in two short sounds from the buzzer. The throttle control will operate when in the Trolling Speed Control mode, but once the speed reaches 3,000 RPM, the Trolling Speed Control is deactivated. If 3,000 RPM is not reached and the throttle is

closed, the engine speed will decrease to the Trolling Speed Control setting.

OPERATION

TRIM TAB

If steering effort is not equal in both directions, adjust the trim tab to compensate for "torque steer," which is the reaction of the outboard motor to propeller rotation.

BF60A models:

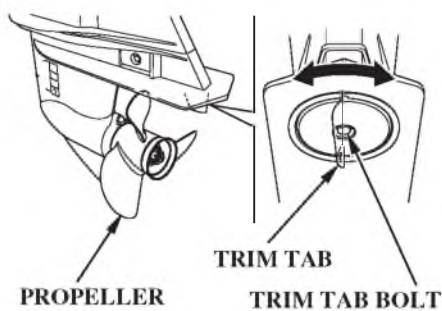

BFP60A models:

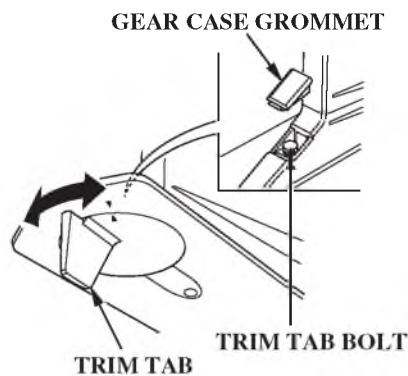

Adjust the trim tab with the engine stopped. Remove the gear case grommet (BFP60A models). Loosen the bolt above the trim tab, turn the trim tab, and then tighten the bolt securely.

When the trim tab is correctly adjusted, steering effort will be equal in both directions.

Refer to *TRIM TAB ADJUSTMENT* on p. 77.

SHALLOW WATER OPERATION

When operating in shallow water, use the power trim/tilt switch (p. 66) to tilt the outboard motor so that the propeller and gear case won't hit the bottom.

Proceed at low speed, and monitor water flow from the cooling system indicator (p. 39) to be sure the outboard motor is not tilted so high that the water intakes are out of the water.

NOTICE

An excessive trim/tilt angle during operation can cause propeller ventilation, overheating, and water pump damage. This type of damage is not covered by the Distributor's Limited Warranty (p. 129).

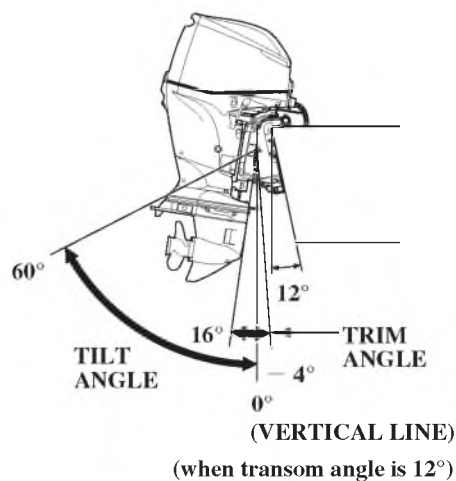

OPERATION

MOORING, BEACHING, LAUNCHING

Before tilting up, leave the outboard motor in the running position for one minute after stopping the engine to drain the water from inside the engine.

To raise the outboard motor out of the water while the engine is stopped and the boat is moored, or for maximum clearance when beaching or launching, use the power tilt switch on the engine pan to tilt the outboard motor up as far as it will go. Move the tilt lock lever to the LOCK position, and then gently lower the outboard motor until the lever contacts the stern bracket.

If more clearance is needed to swing the tilt lock lever into the LOCK position, rock the outboard motor forward slightly by pulling on the engine cover grip.

To lower the outboard motor, tilt up, move the tilt lock lever to the FREE position, and then lower the outboard motor to the desired position.

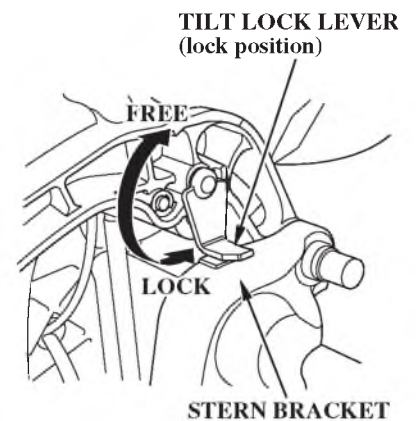
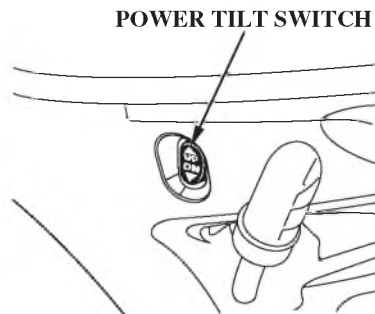

NOTICE

Do not attempt to use the power tilt switch to tilt the outboard motor down while the tilt lock lever is in the LOCK position. Damage to the power tilt system may occur.

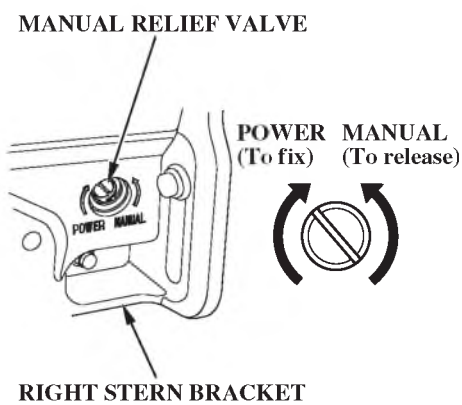

The outboard motor can also be tilted manually after opening the manual relief valve. This feature enables the outboard motor to be tilted up or down when no battery is connected.

For manual tilting, use a flat blade screwdriver to turn the valve counterclockwise 3 and a half turns. Close the valve firmly after positioning the outboard motor.

Check that nobody is under the outboard motor before opening the manual relief valve. If the manual relief valve is loosened (turned counterclockwise) when the outboard motor is tilted up, the outboard motor will suddenly tilt down.

Be sure the valve is closed before operating the outboard motor. If the valve is not closed, the outboard motor will tilt up when operated in reverse.

SERVICING YOUR OUTBOARD MOTOR

THE IMPORTANCE OF MAINTENANCE

Proper maintenance is essential for safe, economical, and trouble-free operation. It will also help reduce air pollution.

⚠ WARNING

Improperly maintaining this outboard motor or failure to correct a problem before operation can cause a malfunction in which you could be seriously hurt or killed.

Always follow the inspection and maintenance recommendations and schedules in this Owner's Manual.

To help you properly care for your outboard motor, the following pages include a maintenance schedule, routine inspection procedures, and simple maintenance procedures using basic hand tools. Other service tasks that are more difficult or require special tools are best handled by professionals and are normally performed by a Honda technician or other qualified mechanic.

The maintenance schedule applies to normal operating conditions. If you operate your outboard motor under unusual conditions, consult an authorized Honda Marine dealer for recommendations applicable to your individual needs and use.

Remember that your authorized Honda Marine dealer knows your outboard motor best and is fully equipped to maintain and repair it.

To ensure the best quality and reliability, use only new, Honda Genuine parts or their equivalents for repair and replacement.

Maintenance, replacement, or repair of the emission control devices and systems may be performed by any marine engine repair establishment or individual, using parts that are “certified” to EPA standards.

SERVICING YOUR OUTBOARD MOTOR

MAINTENANCE SAFETY

Some of the most important safety precautions follow. However, we cannot warn you of every conceivable hazard that can arise in performing maintenance. Only you can decide whether or not you should perform a given task.

⚠ WARNING

Failure to properly follow maintenance instructions and precautions can cause you to be seriously hurt or killed.

Always follow the procedures and precautions in the Owner's Manual.

Safety Precautions

- Make sure the engine is off before you begin any maintenance or repairs. This will eliminate several potential hazards:
 - **Carbon monoxide poisoning from engine exhaust.**
Do not start or run the engine in a confined or partly enclosed area.
 - **Burns from hot parts.**
Let the engine and exhaust system cool before touching.
 - **Injury from moving parts.**
Do not run the engine unless instructed to do so.
- Read the instructions before you begin, and make sure you have the tools and skills required.
- To reduce the possibility of fire or explosion, be careful when working around gasoline. Use only a nonflammable solvent, not gasoline, to clean parts. Keep cigarettes, sparks, and flames away from all fuel-related parts.
- Wear gloves when handling the propeller to protect your hands from sharp edges.

SERVICING YOUR OUTBOARD MOTOR

TOOL KIT and OWNER'S MANUAL

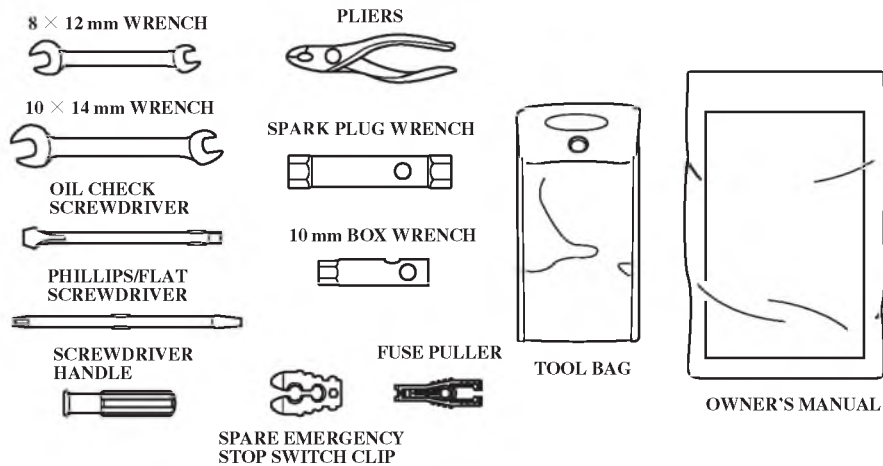

The tool kit can be used for simple maintenance procedures and emergency repairs. Keep these items on the boat so that they will always be available if you need them.

Always carry a spare emergency stop switch clip onboard. The spare clip may either be stored in the tool bag or in an easily accessible location on the boat.

If your tool kit needs replacement, it is not available as a kit and each item must be ordered individually.

EMERGENCY STARTER ROPE



EMERGENCY STARTER ROPE

An emergency starter rope is supplied. Keep the emergency starter rope on the boat, so it will always be available if you need it.

SERVICING YOUR OUTBOARD MOTOR

MAINTENANCE SCHEDULE

Follow the MAINTENANCE SCHEDULE table and service your outboard motor accordingly. Please note, a claim for warranty coverage will not be denied simply because the maintenance schedule for your outboard was not followed. However, any part(s) that fails specifically due to lack of maintenance, or improperly performed maintenance, would not be covered under the *Distributor's Limited Warranty*.

REGULAR SERVICE PERIOD (3) Perform at every indicated month or operating hour interval, whichever comes first.		Each use	After use	First month or 20 hrs.	Every 6 months or 100 hrs.	Every year or 200 hrs.	Every 2 years or 400 hrs.	Refer to page
ITEM								
Engine oil	Check level	<input type="radio"/>						80
	Change			<input type="radio"/>	<input type="radio"/>			81
Gear case oil	Change			<input type="radio"/> (2)	<input type="radio"/> (2)			—
Engine oil filter	Replace					<input type="radio"/> (2)		—
Timing belt	Check-adjust					<input type="radio"/> (2)		—
Throttle linkage	Check-adjust			<input type="radio"/> (2)	<input type="radio"/> (2)			—
Idle speed	Check-adjust			<input type="radio"/> (2)	<input type="radio"/> (2)			—
Valve clearance	Check-adjust					<input type="radio"/> (2)		—
Spark plug	Check-adjust				<input type="radio"/>			83 – 84
	Replace					<input type="radio"/>		
Propeller and cotter pin	Check	<input type="radio"/>						94
Anode metal (Outside engine)	Check	<input type="radio"/>						93
Anode metal (Inside engine)	Check						<input type="radio"/> (2) (7)	—
Lubrication	Grease			<input type="radio"/> (1)	<input type="radio"/> (1)			85 – 86
Fuel tank and tank filter	Clean					<input type="radio"/>		92
Thermostat	Check					<input type="radio"/> (2)		—

(1) Lubricate more frequently when used in salt water.

(2) These items should be serviced by an authorized Honda Marine dealer, unless you have the proper tools and are mechanically proficient. Refer to the Honda shop manual for service procedures.

(3) For professional commercial use, log hours of operation to determine proper maintenance intervals.

(7) Replace the anodes when they have been reduced to about one third their original size, or if they are crumbling.

SERVICING YOUR OUTBOARD MOTOR

REGULAR SERVICE PERIOD (3) Perform at every indicated month or operating hour interval, whichever comes first.		Each use	After use	First month or 20 hrs.	Every 6 months or 100 hrs.	Every year or 200 hrs.	Every 2 years or 400 hrs.	Refer to page
ITEM								
Fuel filter (Low pressure side)	Check Replace	○ (5)			○		○	89-92
Fuel filter (High pressure side)	Check Replace				○ (2)		○ (2)	—
Fuel line	Check Replace	○						—
Battery and cable connection	Check level-tightness	○						—
Bolts and nuts	Check-tightness			○ (2)	○ (2)			—
Crankcase breather tube	Check					○ (2)		—
Cooling water passages	Clean		○ (4)					—
Water pump	Check					○ (2)		—
Emergency stop switch	Check	○						44
Engine oil leak	Check	○						—
Each operation part	Check	○						—
Engine condition (6)	Check	○						—
Power Trim/Tilt	Check				○ (2)			—

(1) Lubricate more frequently when used in salt water.

(2) These items should be serviced by an authorized Honda Marine dealer, unless you have the proper tools and are mechanically proficient. Refer to the Honda shop manual for service procedures.

(3) For professional commercial use, log hours of operation to determine proper maintenance intervals.

(4) When operating in salt water, turbid or muddy water, the engine should be flushed with clean water after each use.

(5) Check for water and/or contamination.

(6) Upon starting, check for unusual engine sounds and cooling water flowing freely from the check hole.

SERVICING YOUR OUTBOARD MOTOR

TRIM TAB ADJUSTMENT

The trim tab compensates for "torque steer," which is a reaction of the outboard motor to propeller rotation.

If uncompensated, torque steer would make the outboard motor tend to turn to one side.

When the trim tab is correctly adjusted, steering effort is equal in either direction.

If steering effort is unequal, remove the gear case grommet (BFP60A models) and loosen the trim tab bolt and adjust the angle of the trim tab. Retighten the trim tab bolt securely. Reinstall the gear case grommet (BFP60A models).

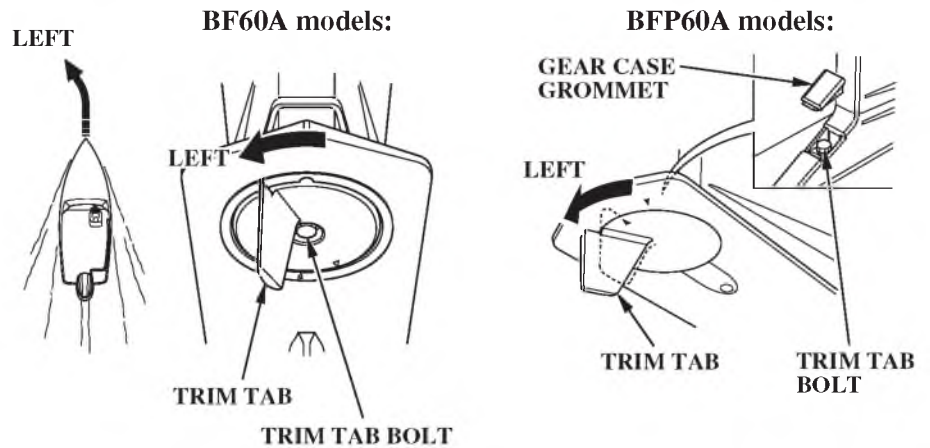

If less effort is required to make left turns, move the back of the trim tab left.

SERVICING YOUR OUTBOARD MOTOR

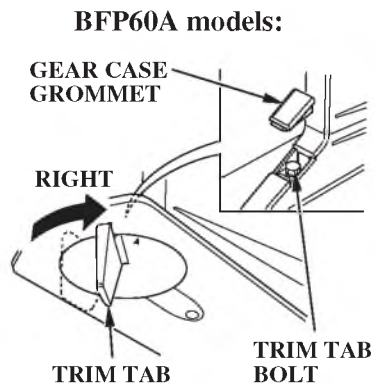
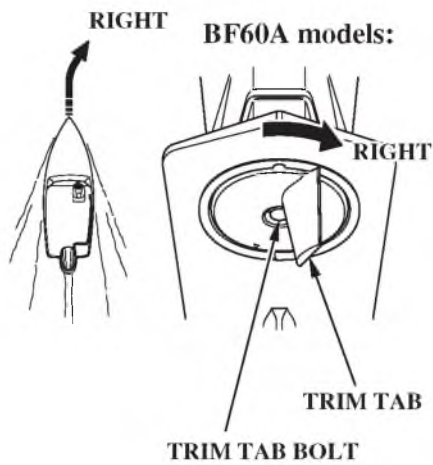

If less effort is required to make right turns, move the back of the trim tab right.

Adjust the trim tab in small increments, and retest steering effort with the boat evenly loaded and running at cruising speed.

SERVICING YOUR OUTBOARD MOTOR

MANUAL RELIEF VALVE

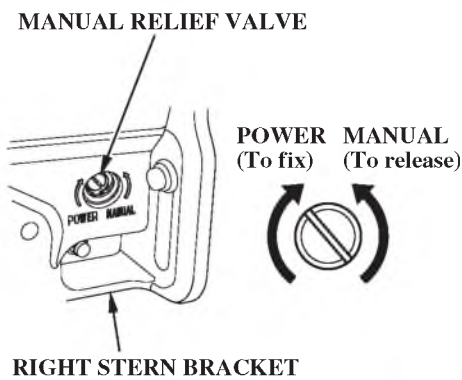

The outboard motor can be tilted manually after opening the manual relief valve. This feature enables the outboard motor to be tilted up or down when no battery is connected.

For manual tilting, use a flat blade screwdriver to turn the valve counterclockwise 3 and a half turns. Close the valve firmly after positioning the outboard motor.

Check that nobody is under the outboard motor before opening the manual relief valve. If the manual relief valve is loosened (turned counterclockwise) when the outboard motor is tilted up, the outboard motor will suddenly tilt down.

Be sure the valve is closed before operating the outboard motor. If the valve is not closed, the outboard motor will tilt up when operated in reverse.

ENGINE COVER REMOVAL AND INSTALLATION

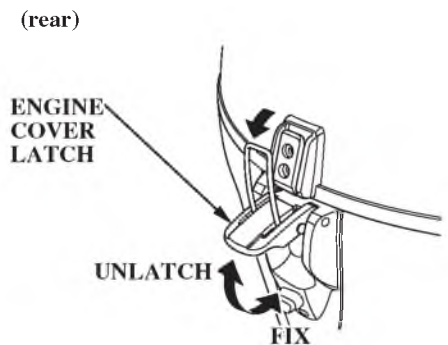
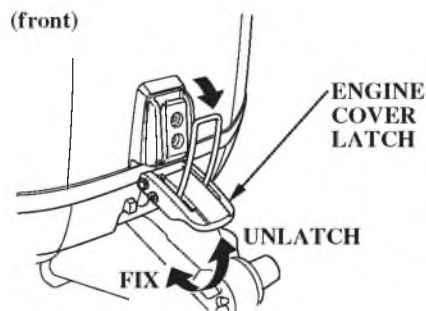

The engine cover latches fasten the engine cover to the outboard motor.

To remove the engine cover, unlatch both front and rear latches, then lift the engine cover off the outboard motor.

To install the engine cover, place the cover on the outboard motor, then latch both front and rear latches securely.

SERVICING YOUR OUTBOARD MOTOR

Engine Oil Level Check

Check the engine oil level with the engine stopped and the outboard motor in the vertical position.

1. Unlatch and remove the engine cover (p. 79).
2. Remove the dipstick and wipe it clean.

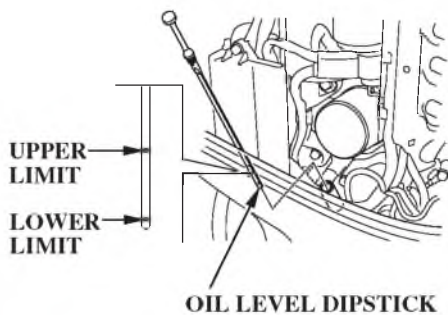

3. Insert the dipstick all the way in, then remove it and check the oil level shown on the dipstick.

OIL FILLER CAP

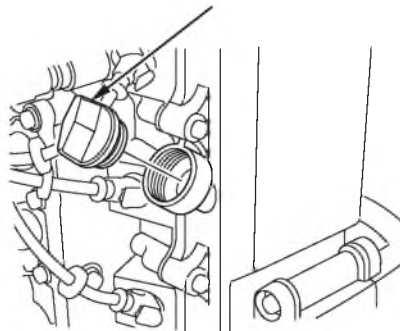

NOTICE

Running the engine with a low oil level can cause engine damage.

4. If the oil level is low, remove the oil filler cap, and add oil to reach the upper limit mark shown on the dipstick. Use the oil recommended on p. 82.
5. Install the oil filler cap and tighten it securely.
6. Install and lock the engine cover.

SERVICING YOUR OUTBOARD MOTOR

Engine Oil Change

An engine oil evacuation device may be used to remove the engine oil.

Drain the used oil while the engine is warm. Warm oil drains quickly and completely.

1. Unlatch and remove the engine cover (p. 79).

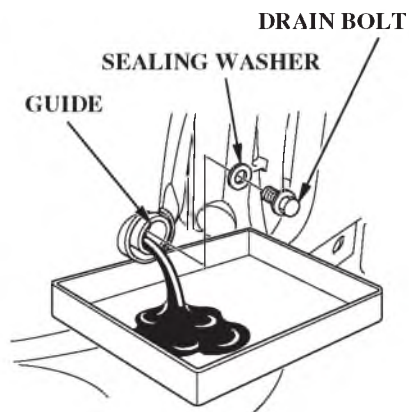

2. Place a suitable container below the oil drain guide to catch the used oil, and then remove the oil filler cap (p. 80) and the drain bolt.
3. Allow the used oil to drain completely. Use a new sealing washer, and then reinstall the engine oil drain bolt and washer. Tighten the drain bolt securely.

DRAIN BOLT TIGHTENING TORQUE:
17 lbf·ft (23 N·m , 2.3 kgf·m)

NOTICE

Improper disposal of engine oil can be harmful to the environment. If you change your own oil, please dispose of the used oil properly. Put it in a sealed container, and take it to a recycling center. Do not throw it in the trash, pour it on the ground or down a drain.

SERVICING YOUR OUTBOARD MOTOR

4. With the outboard motor in a vertical position, fill to the upper limit mark on the dipstick (p. 80) with the recommended oil.
Engine oil refill capacity:
Without oil filter change:
2.7 US qt (2.6 L)
With oil filter change:
2.9 US qt (2.7 L)
5. Install the oil filler cap and tighten it securely (p. 80).
6. Install and lock the engine cover.

Engine Oil Recommendations

Oil is a major factor affecting performance and service life. Use 4-stroke detergent oil.

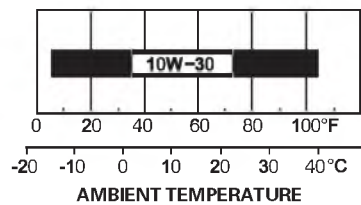

Honda 10W-30 FC-W™ outboard motor oil is recommended for general use.

If Honda 10W-30 FC-W oil is not available, Honda recommends that you use API service category SG, SH or SJ oil with the ‘starburst’ certification mark. The SAE oil viscosity and service category are in the API label on the oil container.

SERVICING YOUR OUTBOARD MOTOR

Spark Plug Service

RECOMMENDED SPARK PLUGS:
LMAR6C-9 (NGK)

NOTICE

Incorrect spark plugs can cause engine damage.

1. Unlatch and remove the engine cover (p. 79).

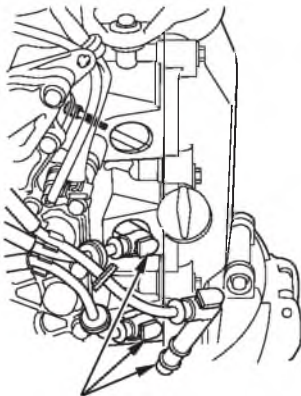

SPARK PLUG CAPS

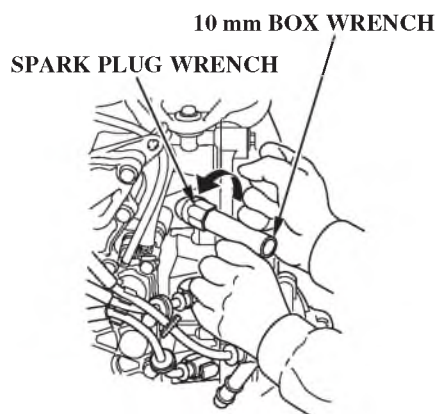

2. Disconnect the spark plug caps from the spark plugs.
3. Remove the spark plugs with a spark plug wrench and 10 mm box wrench.
4. Inspect the spark plugs. Replace them if the electrodes are worn, or if the insulators are cracked or chipped.

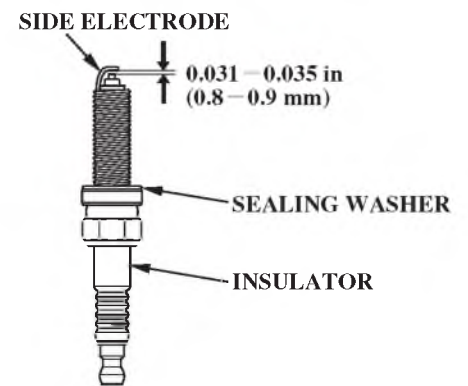

5. Measure the spark plug electrode gap with a wire-type feeler gauge. Correct the gap, if necessary, by carefully bending the side electrode.

The gap should be:
0.031 - 0.035 in
(0.8 - 0.9 mm)

SERVICING YOUR OUTBOARD MOTOR

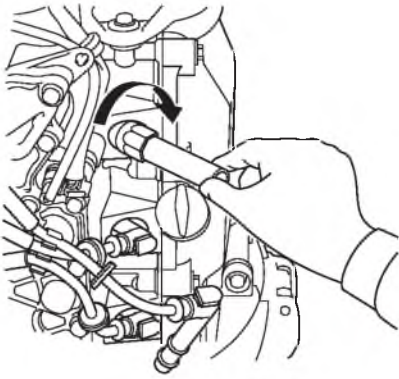

6. Install the spark plugs carefully, by hand, to avoid cross-threading.

7. After each spark plug seats, tighten with a spark plug wrench and 10 mm box wrench to compress the sealing washer.

If reinstalling used spark plugs, tighten 1/8 – 1/4 turn after the spark plugs seat.

If installing new spark plugs, tighten 1/2 turn after the spark plugs seat.

NOTICE

*Loose spark plugs can overheat and damage the engine.
Overtightening the spark plugs can damage the threads in the cylinder head.*

8. Attach the spark plug caps.

9. Install and lock the engine cover.

SERVICING YOUR OUTBOARD MOTOR

Lubrication Points

Apply Honda Marine waterproof grease to the parts shown below:

Lubrication interval:

After the first 20 hours or 1 month, then every 100 hours or 6 months (refer to the maintenance schedule on page 75).

NOTICE

To prevent corrosion, apply anticorrosion oil to pivot surfaces where grease cannot penetrate.

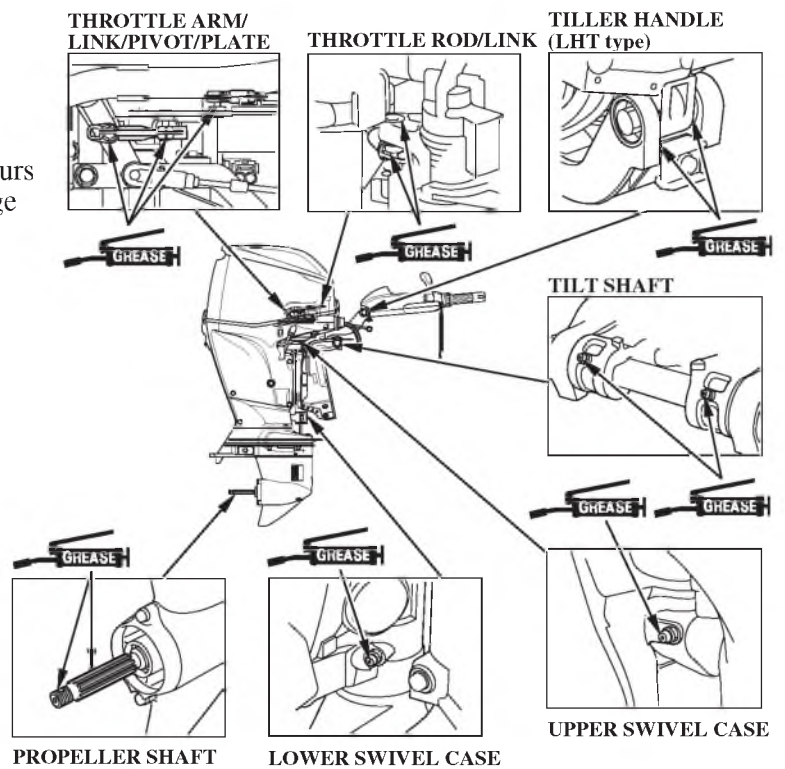

Apply Honda Marine Corrosion Inhibitor (or equivalent) to all areas under the engine cover and any exposed metal surfaces except the belts.

SERVICING YOUR OUTBOARD MOTOR

SHIFT LINK BRACKET/
SHIFT PIVOT/SHIFT
ARM/LINK PIN/PIVOT
PLATE/SLIDE PIVOT/
CLICK SPRING
ROLLER

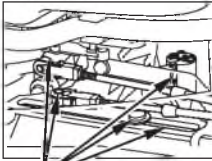

GREASE

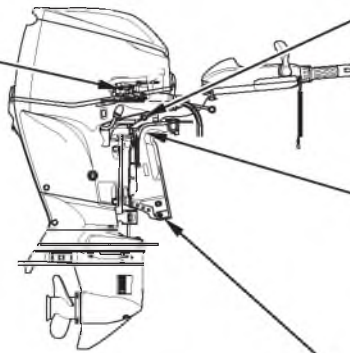

TILT LOCK LEVER
(each side)

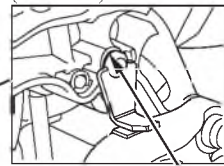

GREASE

UPPER CYLINDER
PIN/BUSHING

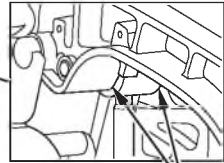

GREASE

GREASE

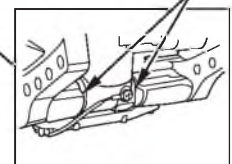

LOWER CYLINDER
BUSHING/COLLAR

SERVICING YOUR OUTBOARD MOTOR

REFUELING

Portable Fuel Tank (optional equipment)

FUEL TANK CAPACITY:

6.6 US gal (25 L)

Check the fuel gauge and refill the tank when necessary.

Remove the fuel tank from the boat for refueling.

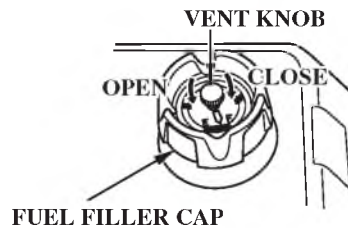

To refuel, turn the vent knob counterclockwise to the OPEN position, and unscrew the fuel filler cap.

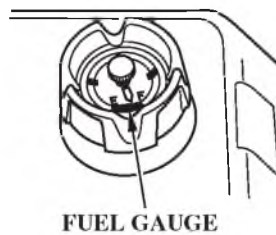

SAFE FILL LEVEL

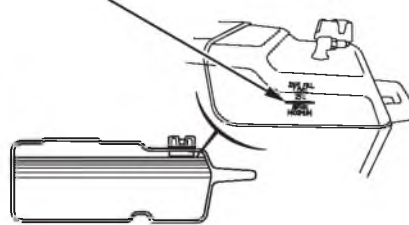

Refuel in a well-ventilated area. Fill the tank to the SAFE FILL LEVEL line.

After refueling, install the cap and tighten it securely. Turn the vent knob clockwise to the CLOSED position, and return the fuel tank to the boat.

Using the fuel tank mounted in the boat.

Check the fuel level and refill if necessary. Do not fill the fuel tank above the UPPER LIMIT. Refer to the boat manufacturer's instructions.

NOTICE

Fuel can damage paint and plastic. Be careful not to spill fuel when filling your fuel tank. Damage caused by spilled fuel is not covered under warranty.

SERVICING YOUR OUTBOARD MOTOR

⚠ WARNING

Gasoline is highly flammable and explosive.

You can be burned or seriously injured when handling fuel.

- Stop the engine and keep heat, sparks, and flame away.
- Handle fuel only outdoors.
- Wipe up spills immediately.

Never refill the fuel tank inside a building where gasoline fumes may reach flames or sparks. Keep gasoline away from appliance pilot lights, barbecues, electric appliances, power tools, etc.

Spilled fuel is not only a fire hazard, it causes environmental damage. Wipe up spills immediately.

FUEL RECOMMENDATIONS

Use unleaded gasoline with a pump octane rating of 86 or higher.

Your outboard motor is certified to operate on unleaded gasoline. Unleaded gasoline produces fewer engine and spark plug deposits and extends exhaust system life.

Never use stale or contaminated gasoline or an oil/gasoline mixture. Avoid getting dirt or water in the fuel tank.

You may use unleaded gasoline containing no more than 10% ethanol (E10) or 5% methanol by volume. In addition, methanol must contain cosolvents and corrosion inhibitors.

Use of fuels with content of ethanol or methanol greater than shown above may cause starting and/or performance problems. It may also damage metal, rubber, and plastic parts of the fuel system.

Engine damage or performance problems that result from using a fuel with percentages of ethanol or methanol greater than shown above are not covered under warranty. If your outboard will be used on an infrequent or intermittent basis, please refer to the fuel section of the STORAGE chapter (p. 98) for additional information regarding fuel deterioration.

SERVICING YOUR OUTBOARD MOTOR

Fuel Filter/Water Separator Inspection and Service

The fuel filter is located near the engine cover latch on the boat side.

Water or sediment accumulation in the filter can cause loss of power or hard starting. To prevent engine malfunction, inspect the filter and replace when necessary.

A red ring float is located inside the strainer cup. It floats on top of the water and indicates how much water has accumulated in the strainer cup.

⚠ WARNING

Gasoline is highly flammable and explosive.

You can be burned or seriously injured when handling fuel.

- Stop the engine and keep heat, sparks, and flame away.
- Handle fuel only outdoors.
- Wipe up spills immediately.

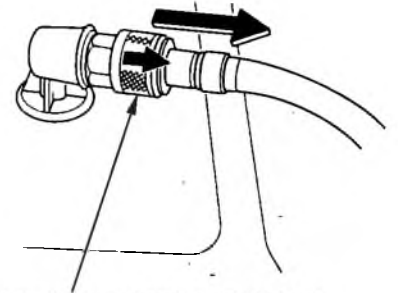

FUEL TANK HOSE ASSEMBLY CONNECTOR

1. Remove the engine cover (p. 79) and disconnect the fuel tank hose assembly connector from the fuel tank.

SERVICING YOUR OUTBOARD MOTOR

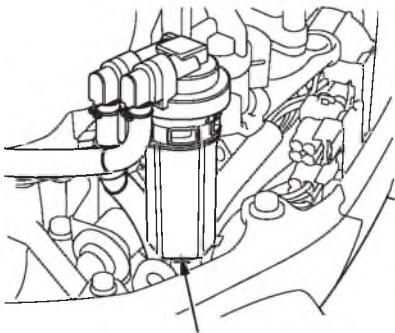

FUEL FILTER
(inside strainer cup)

2. Inspect the filter for water and/or sediment accumulation.

If water and/or sediment are present, clean the strainer cup and filter or replace the filter as described in the following steps. Always replace the filter at the scheduled replacement interval (p. 76).

FUEL FILTER BRACKET

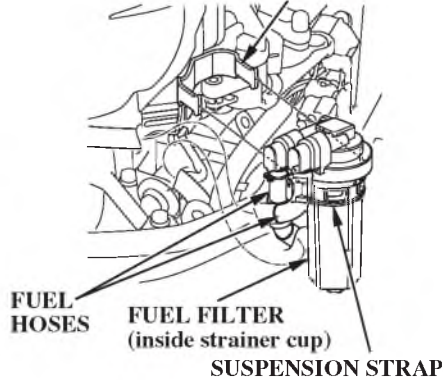

3. Remove the suspension strap from the fuel filter bracket, and then remove the strap from the fuel filter assembly.

4. Place commercially available hose clips on the fuel hoses on each side of the filter to prevent fuel leakage when the fuel hoses are disconnected.

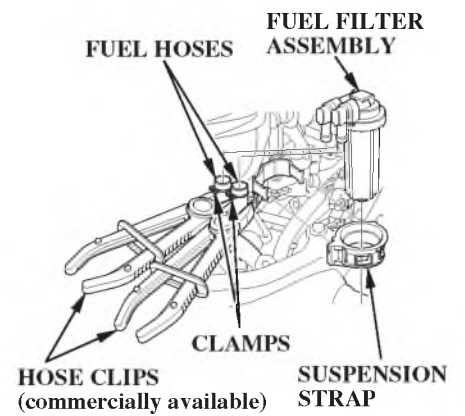

5. Disconnect the fuel tubes from the fuel filter assembly.

SERVICING YOUR OUTBOARD MOTOR

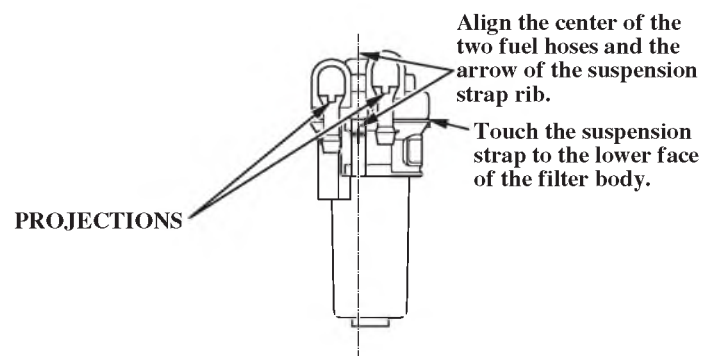
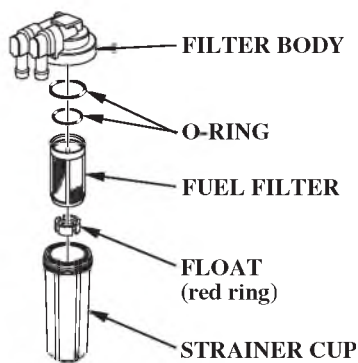

6. Unscrew the strainer cup from the filter body.

7. Thoroughly clean the strainer cup and fuel filter.
If the fuel filter is contaminated, replace it with a new one.

8. Install the fuel filter, float, O-rings and strainer cup.

TIGHTENING TORQUE:
2.2 lbf·ft (3 N·m, 0.3 kgf·m)

9. Install the suspension strap to the fuel filter assembly as shown above.

10. Reinstall the fuel filter assembly and suspension strap in the reverse order of removal.

SERVICING YOUR OUTBOARD MOTOR

11. Align the white paint on the fuel hoses and the projections of the filter body.
Connect the fuel hoses to the fuel filter securely with the hose clamps. Remove the fuel hose clips used to close the fuel hoses.
12. Securely connect the fuel tank hose assembly connector to the outboard motor (refer to page 48).
13. Prime the engine using the priming bulb (p. 49). Check for fuel leaks. Repair any fuel leaks if necessary.

If loss of power or hard starting are found to be caused by excessive water or sediment accumulation in the fuel filter, inspect the fuel tank.

Clean the fuel tank and tank filter if necessary. It may be necessary to drain the fuel tank completely and refill with fresh gasoline.

Portable Fuel Tank and Tank Filter Cleaning (optional equipment)

⚠ WARNING

Gasoline is highly flammable and explosive.

You can be burned or seriously injured when handling fuel.

- Stop the engine and keep heat, sparks, and flame away.
- Handle fuel only outdoors.
- Wipe up spills immediately.

Fuel Tank

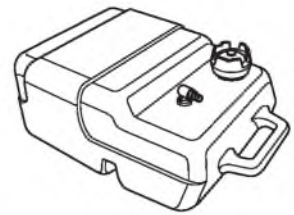

Empty the portable fuel tank into an approved gasoline container. Use a funnel to avoid spilling fuel. Rinse the fuel tank with nonflammable solvent to remove any accumulated sediment.

SERVICING YOUR OUTBOARD MOTOR

Fuel Tank Filter

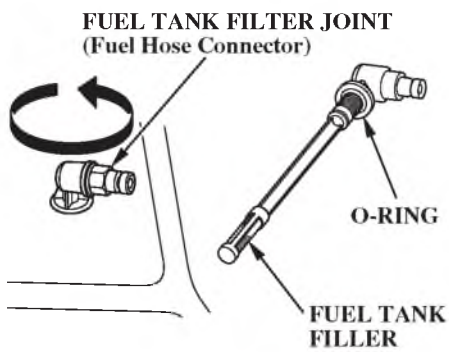

1. Unscrew the fuel hose connector by turning it counterclockwise; then remove the fuel hose connector and fuel tank filter from the tank.
2. Clean the filter in nonflammable solvent. Inspect the fuel tank filter and the connector O-ring. Replace them if damaged.
3. Reinstall the filter and hose connector in the fuel tank. Tighten the hose connector securely.

Anode Replacement

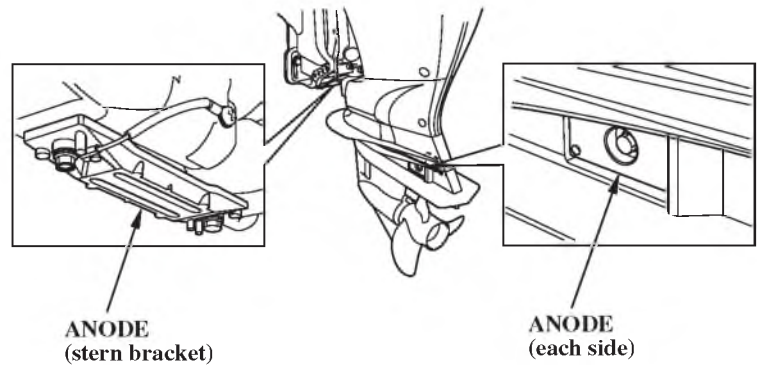

The anodes are located on each side of the gear case and on the stern bracket. They are made of a sacrificial material that helps to protect the outboard motor from corrosion.

Replace the anodes when they have been reduced to about one third their original size, or if they are crumbling.

NOTICE

Painting or coating the anodes will defeat their purpose and will lead to rust and corrosion damage to the outboard motor. The anodes must be exposed to the water in order to protect the outboard motor.

SERVICING YOUR OUTBOARD MOTOR

Propeller Replacement

Before replacing the propeller, remove the emergency stop switch clip from the emergency stop switch to prevent any possibility of the engine being started while you are working with the propeller. The propeller blades may have sharp edges, so wear heavy gloves to protect your hands.

Operating the outboard motor at higher altitudes will reduce available power. This may require decreasing the propeller pitch to maintain correct engine RPM.

Removal

1. Remove the cotter pin, unscrew the castle nut, remove the spacer (BF60A models only), plain washer, and then remove the propeller and thrust washer.
2. Inspect the propeller shaft for any fishing line or debris.

Installation

1. Apply marine grade grease to the propeller shaft.
2. Install the thrust washer with the grooved side toward the gear case.
3. Install the propeller.
4. Install the spacer (BF60A models only) and plain washer.
5. Lightly tighten the castle nut by hand or wrench until the propeller has no free play.
6. Tighten the castle nut using a torque wrench.
CASTLE NUT
TIGHTENING TORQUE:
0.7 lbf·ft (1 N·m, 0.1 kgf·m)
7. Then, using a torque wrench, tighten the castle nut until the first available groove in the castle nut aligns with the cotter pin hole. Do not tighten past the first alignment

of the castle nut groove and the cotter pin hole.

NOTICE

TIGHTENING TORQUE LIMIT:

BF60A models

25 lbf·ft (35 N·m , 3.5 kgf·m)

BFP60A models

33 lbf·ft (44 N·m , 4.5 kgf·m)

Do not tighten the castle nut above the TIGHTENING TORQUE LIMIT, or the propeller and shaft may be damaged.

SERVICING YOUR OUTBOARD MOTOR

8. Be sure to replace the cotter pin with a new one.

- Use a Honda Genuine stainless steel cotter pin or equivalent cotter pin and bend the pin ends as shown.

Note that these wrenches are not included with the tool set that comes with the outboard motor. Contact your authorized Honda Marine dealer for additional tool information.

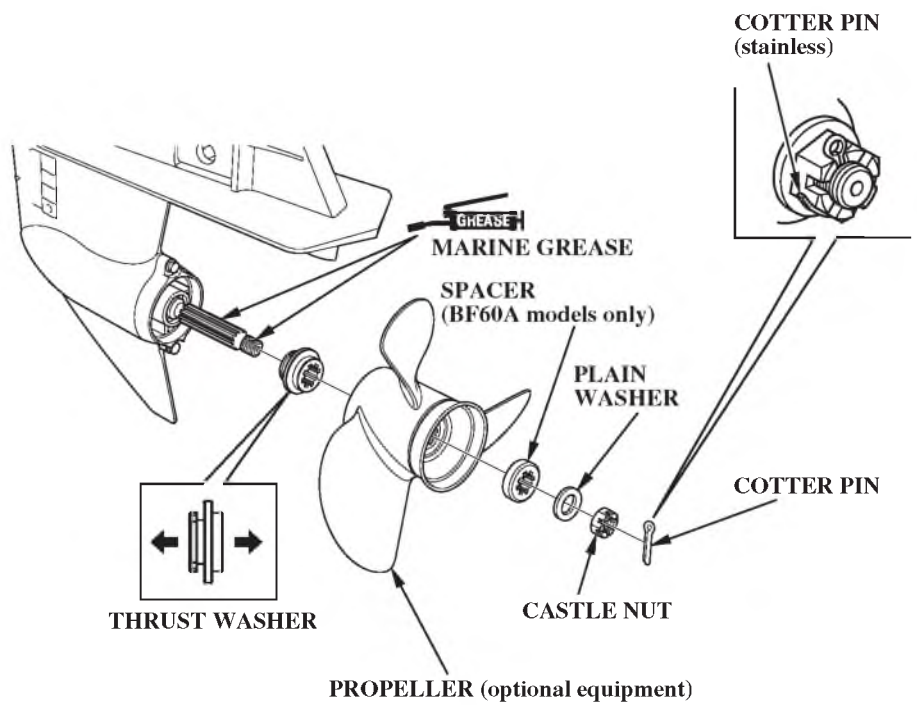

STORAGE

STORAGE PREPARATION

Proper storage preparation is essential for keeping your outboard motor trouble-free and looking good. The following steps will help to keep rust and corrosion from impairing your outboard motor's function and appearance, and will make the engine easier to start when you use the outboard motor again.

Cleaning and Flushing

Thoroughly clean and flush the outboard motor with fresh water after operation in dirty water or salt water.

Touch up any damaged paint, and coat areas that may rust with Honda Corrosion Inhibitor, or equivalent. Lubricate controls with a silicone spray lubricant.

Cleaning

Wash the outside of the outboard motor with clean, fresh water, and flush the cooling system as follows.

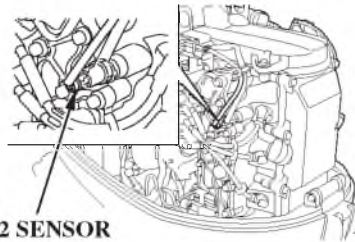

HO2 SENSOR

NOTICE

Do not apply water or corrosion inhibitor directly to the electrical components under the engine cover, such as the HO2 sensor and timing belt. If water or corrosion inhibitor penetrates these components, they may be damaged. Before applying a corrosion inhibitor, cover the HO2 sensor and timing belt with a protective material to prevent damage.

Flushing With a Garden Hose (commercially available)

NOTICE

Do not run the motor when flushing the motor with a garden hose or the motor may be damaged.

For safety, remove the emergency stop switch clip so the engine cannot be started while you are standing near the propeller.

1. Tilt down the outboard motor.
2. Clean and wash the outside of the outboard motor with fresh water.

STORAGE

**FLUSH PORT
CONNECTOR**

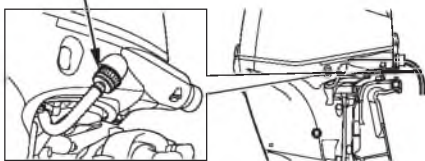

**FLUSH PORT
CONNECTOR**

3. Disconnect the flush port connector.

**FLUSH PORT
CONNECTOR** **GARDEN HOSE**

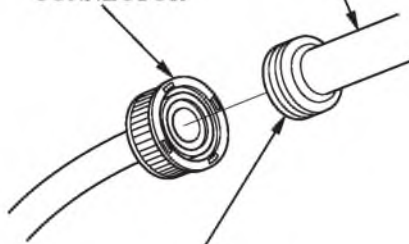

GARDEN HOSE JOINT
(Commercially available)

4. Screw the flush port connector onto the garden hose.

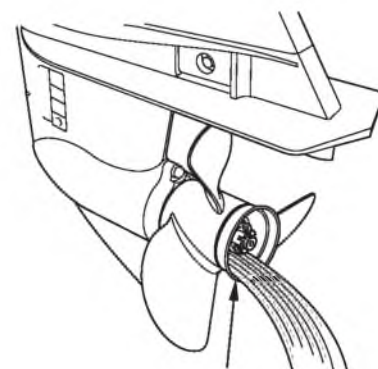

EXHAUST PORT

5. Turn on the fresh water supply and flush the outboard motor for at least 10 minutes.
6. After flushing, disconnect the garden hose and reconnect the flush port connector.
7. Tilt up the outboard motor and move the tilt lock lever to the LOCK position.

STORAGE

Fuel

Gasoline will oxidize and deteriorate in storage. Old gasoline will cause hard starting, and it leaves gum deposits that clog the fuel system. If the gasoline in your fuel tank and vapor separator deteriorates during storage, you may need to have the vapor separator and other fuel system components serviced or replaced.

The length of time that gasoline can be left in your fuel tank and vapor separator without causing functional problems will vary with such factors as gasoline blend, your storage temperatures, and whether the fuel tank is partially or completely filled. The air in a partially filled fuel tank promotes fuel deterioration. Very warm storage temperatures accelerate fuel deterioration. Fuel deterioration problems may occur within a few months, or even less if the gasoline was not fresh when you filled the fuel tank.

You can extend fuel storage life by adding a gasoline stabilizer that is formulated for that purpose, or you can avoid fuel deterioration problems by draining all the fuel from the fuel tank and vapor separator.

The *Distributor's Limited Warranty* does not cover fuel system damage or engine performance problems resulting from neglected storage preparation.

Adding a Fuel Stabilizer

When adding a fuel stabilizer, fill the fuel tank with fresh gasoline. If only partially filled, air in the tank will promote fuel deterioration during storage. If you keep an additional container of gasoline for refueling, be sure that it contains only fresh gasoline.

1. Drain the vapor separator before adding fuel stabilizer.
2. Add fuel stabilizer following the manufacturer's instructions.
3. After adding a fuel stabilizer, run the engine in water for 10 minutes to be sure that the treated gasoline has replaced the untreated gasoline in the vapor separator.
4. Turn the engine OFF.

Draining the Fuel System

You can avoid fuel deterioration problems by draining the fuel tank and vapor separator. Before draining and checking the fuel system, check the fuel filter for contamination and/or water accumulation. The fuel filter must be free of any contamination before proceeding (p. 89). Draining the vapor separator will not drain the fuel filter bowl.

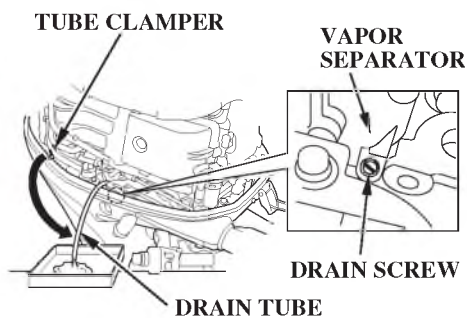

1. Disconnect the fuel tank hose assembly connector from the fuel tank (p. 89).
2. Remove the engine cover (p. 79).
3. Release the drain tube from its clamp along the high pressure fuel hose and set the end of the tube toward the outside of the engine undercase. Place an approved gasoline container below the end of the tube, and use a funnel to avoid spilling gasoline.
4. Loosen the vapor separator drain screw.

⚠ WARNING

Gasoline is highly flammable and explosive.

You can be burned or seriously injured when handling fuel.

- Stop the engine and keep heat, sparks, and flame away.
- Handle fuel only outdoors.
- Wipe up spills immediately.

STORAGE

5. Tilt the outboard motor up until gasoline flows out of the drain tube.
6. Leave it in that position until the gasoline stops flowing.
7. After thoroughly draining, tighten the drain screw securely.
8. Check the drained gasoline for the presence of water or contamination. If either is present, you will have to reassemble and run the outboard to refill the vapor separator with gasoline and then drain it again. Repeat the following procedure until no water or contamination is present in the removed gasoline.
 - a. Make sure the gasoline supply is not contaminated.
 - b. Reassemble the outboard and reconnect the fuel line connector.
 - c. Place the outboard in water. Use the priming bulb to refill the fuel system and run the outboard at idle for 3 minutes.
 - d. Stop the outboard and follow the procedure beginning with step 1 above.
9. Secure the drain tube to the clamp along the high pressure fuel hose.
10. Install the engine cover.
11. Drain the fuel tank into an approved gasoline container, or if you need to store fuel in the fuel tank, you can extend fuel storage life by filling the fuel tank with fresh gasoline and adding a fuel stabilizer that is formulated for that purpose.

STORAGE

Engine Oil

1. Change the engine oil (p. 81).
2. Remove the spark plugs (p. 83), and remove the emergency stop switch clip from the emergency stop switch.
3. Pour 1–2 teaspoons (5 – 10 cm³) (p. 116) of clean engine oil into each cylinder.
4. Using the emergency starter rope (p. 57), rotate the flywheel a few revolutions to distribute the oil in the cylinders.
5. Reinstall the spark plugs (p. 83).

HOISTING THE OUTBOARD MOTOR

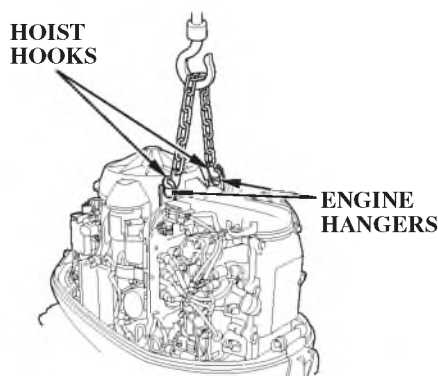

1. Unlatch and remove the engine cover (p. 79).
2. Attach the hoist hooks to the engine hangers.
3. Disconnect the outboard motor from the boat, hoist the outboard motor, and move it to the storage area.

4. After the outboard motor is placed in storage and disconnected from the hoist, install the engine cover.

STORAGE PRECAUTIONS

Select a well-ventilated storage area. If possible, avoid storage areas with high humidity.

If storing a container of gasoline, such as the portable fuel tank (optional equipment), store it away from any appliance that operates with a flame, such as a furnace, water heater, or clothes dryer. Also avoid any area with a spark producing electric motor, or where power tools are operated.

STORAGE



OUTBOARD MOTOR STAND
(commercially available)

If the outboard motor will be removed from the boat for storage, we recommend storing it vertically by mounting it on a commercially available stand.

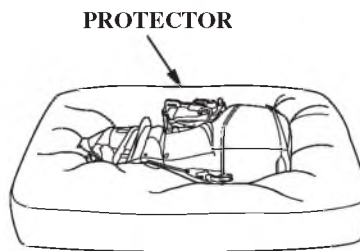

(Starboard side turned down as shown.)

If it is necessary to store the outboard motor horizontally as shown, drain the vapor separator (p. 99), and drain the engine oil (p. 81), before removing the outboard motor from the boat.

Rest the motor on a cushion of protective material.

NOTICE

Any other horizontal storage position may cause damage to the outboard motor or oil leakage.

Cover the outboard motor to keep out dust. Do not use plastic sheet as a dust cover. A nonporous cover will trap moisture, promoting rust and corrosion.

REMOVAL FROM STORAGE

Check your outboard motor as described in the *BEFORE OPERATION* chapter of this manual.

If the cylinders were coated with oil during storage preparation, the engine may smoke briefly at startup. This is normal.

TRANSPORTING

WITH OUTBOARD MOTOR INSTALLED ON BOAT

When trailering a boat with the outboard motor attached, leave the engine in the normal running position, if possible.

LHT Type (tiller handle)

STEERING FRICTION ADJUSTER

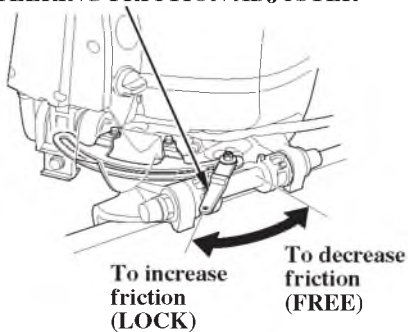

Tighten the steering friction adjuster to prevent the outboard motor from moving while trailering the boat.

LRT and XRT Types (remote control)

Use a motor support bar to prevent the outboard motor from moving while trailering the boat. Refer to the manufacturer's instructions for using a motor support bar.

All Types

If there is insufficient road clearance in the normal running position, then tilt the outboard motor and use a motor support bar, or remove the outboard motor from the boat. Refer to the manufacturer's instructions for using a motor support bar.



MOTOR SUPPORT BAR
(commercially available)

WITH OUTBOARD MOTOR REMOVED FROM BOAT

Secure the outboard motor in either the vertical or horizontal position shown on p.102.

TAKING CARE OF UNEXPECTED PROBLEMS

ENGINE WILL NOT START	Possible Cause	Correction
1. Check emergency stop switch clip.	Clip not inserted in emergency stop switch.	Insert clip in emergency stop switch.
2. Check control positions.	Gearshift lever or control lever not in neutral position.	Shift to neutral (p. 50 or p. 53).
	Throttle grip not in START position (tiller handle type).	Turn throttle grip to START position (p. 51).
	Fast idle lever raised (remote control/side-mount type).	Leave fast idle lever in the START position (p. 54).

TAKING CARE OF UNEXPECTED PROBLEMS

ENGINE WILL NOT START (continued)	Possible Cause	Correction
3. Check fuel.	Out of fuel.	Refuel (p. 87).
	Fuel vent closed (portable fuel tank — optional equipment).	Open fuel filler cap vent (p. 49).
	Fuel hose not primed.	Squeeze priming bulb (p. 49).
	Fuel filter or fuel tank filter clogged.	Replace fuel filters (p. 89 and 93).
	Bad fuel; boat stored without treating or draining gasoline, or refueled with bad gasoline.	Drain fuel tank and vapor separator (p. 99). Refill with fresh gasoline (p. 87).

TAKING CARE OF UNEXPECTED PROBLEMS

ENGINE WILL NOT START (continued)	Possible Cause	Correction
4. Check battery.	Battery connections loose or corroded.	Clean and tighten battery connections.
	Battery discharged.	Recharge battery.
5. Check fuses.	Fuse(s) blown.	Replace fuse(s) (p. 109).
6. Remove and inspect spark plugs.	Spark plugs faulty, fouled, or improperly gapped.	Gap or replace spark plugs (p. 83).
	Spark plugs wet with fuel (flooded engine).	Dry and reinstall spark plugs. Start engine with the throttle open.
7. Use starting procedure (p. 50 , 53); if engine still will not start, then take outboard motor to an authorized Honda Marine dealer, or refer to the shop manual.	Fuel system malfunction, fuel pump failure, ignition malfunction, stuck valves, starter malfunction, switch malfunction, or electrical problem in the starting circuit, etc.	Replace or repair faulty components as necessary.

TAKING CARE OF UNEXPECTED PROBLEMS

HARD STARTING OR STALLS AFTER STARTING	Possible Cause	Correction
1. Check control positions.	Throttle grip not in START position (tiller handle type).	Turn throttle grip to START position (p. 51).
	Fast idle lever raised (remote control/side-mount type).	Leave fast idle lever in the START position (p. 54).
2. Check fuel.	Fuel vent closed (portable fuel tank — optional equipment).	Open fuel filler cap vent (p. 49).
	Fuel hose not primed.	Squeeze priming bulb (p. 49).
	Fuel filter or fuel tank filter clogged.	Replace fuel filters (p. 89 and 93).
	Bad fuel; boat stored without treating or draining gasoline, or refueled with bad fuel.	Drain fuel tank and vapor separator (p. 99). Refill with fresh gasoline (p. 87).

TAKING CARE OF UNEXPECTED PROBLEMS

HARD STARTING OR STALLS AFTER STARTING (continued)	Possible Cause	Correction
3. Remove and inspect spark plugs.	Spark plugs faulty, fouled, or improperly gapped.	Gap or replace spark plugs (p. 83).
4. Take outboard motor to an authorized Honda Marine dealer, or refer to the shop manual.	Fuel system malfunction, fuel pump failure, ignition malfunction, etc.	Replace or repair faulty components as necessary.

ENGINE OVERHEATS	Possible Cause	Correction
1. Check water intake screens.	Water intake screens clogged.	Clean water intake screens.
2. Take outboard motor to an authorized Honda Marine dealer, or refer to the shop manual.	Faulty thermostat or water pump.	Replace or repair faulty components as necessary.

TAKING CARE OF UNEXPECTED PROBLEMS

FUSES

Electric Starter Will Not Operate

The 10A, 15A, and 30A fuses protect the electric starter relay and related circuits.

The 10A ② fuse protects the ignition switch and related circuits. If this fuse blows, the engine will not start or run, and the power trim/tilt switch will not activate the trim/tilt mechanism.

Battery Will Not Charge

A 40A ACG fuse protects the alternator circuit. If the ACG fuse blows, the engine will not charge the battery. Refer to p. 111.

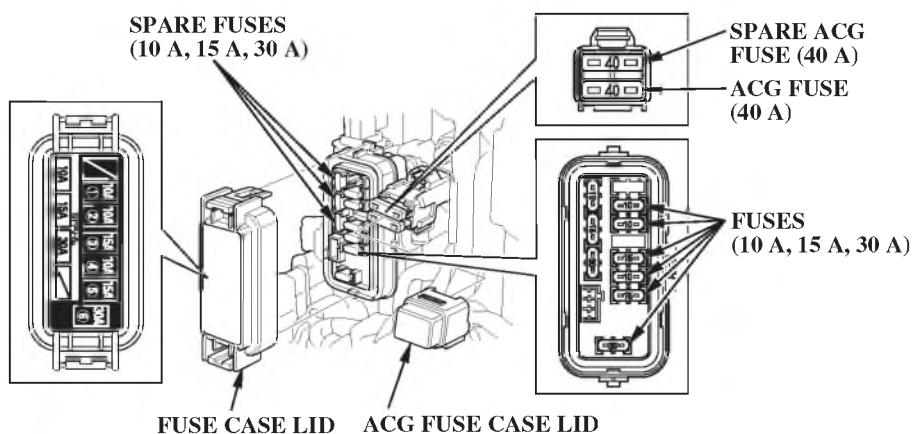

Fuse No.	Rating	Connected Components
	40 A	Alternator (regulator rectifier-battery charging)
①	10 A	Fuel pump (high pressure side)
②	10 A	Power trim/tilt relay, Main relay, Warning buzzer, Indicator, Starter solenoid switch, each meters
③	15 A	PGM-FI ECM, Fuel injectors, CKP sensor 1, 2
④	10 A	Data link connector, HO2 sensor heater, Indicator cable
⑤	15 A	PGM-FI ECM, Ignition coils
⑥	30 A	Gathered fuse (No. 1, 3, 4, 5 Fuses)

TAKING CARE OF UNEXPECTED PROBLEMS

Fuse Replacement

NOTICE

Disconnect the battery cable at the battery negative (–) terminal before replacing the fuse. Failure to do so may cause a short circuit.

Main Fuse

1. Stop the engine and disconnect the battery cable.
2. Remove the fuse case lid.

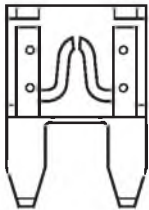

BLOWN FUSE

FUSE PULLER
(supplied in the tool bag)

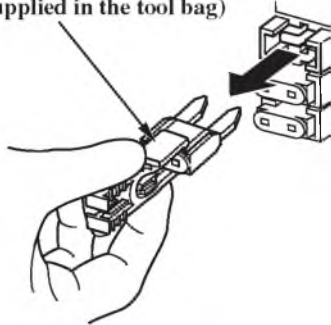

3. Use the fuse puller from the tool kit to remove the fuses. If a fuse is blown, install a replacement fuse of the same specified rating. The outboard motor is supplied with spare fuses in the fuse holder.

MAIN FUSE RATINGS:
10 A, 15 A, 30 A

4. Reinstall the fuse case lid, and the engine cover.

5. Reconnect the battery.

NOTICE

Never use a fuse with a rating greater than specified. Serious damage to the electrical system could result.

If a blown fuse is found, try to determine and correct the electrical problem that caused the blown fuse. An uncorrected electrical problem may cause the fuse to blow again.

If fuses continue to blow, take the outboard motor to an authorized Honda Marine dealer for inspection and service, or refer to the shop manual.

TAKING CARE OF UNEXPECTED PROBLEMS

ACG Fuse

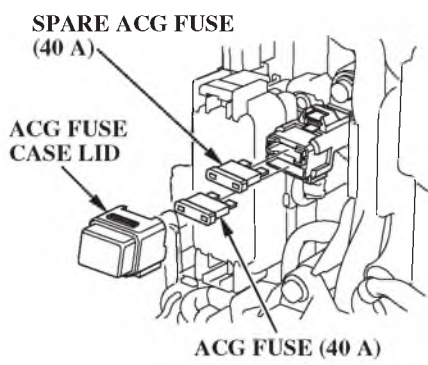

1. Stop the engine and disconnect the battery cable.
2. Remove the engine cover.
3. Remove the fuse case lid.
4. Remove the old fuse.

5. Install a new fuse with the "40A."

ACG FUSE RATING: 40 A

6. Be sure the fuse case lid is securely locked.
7. Reinstall the engine cover.
8. Reconnect the battery.

TAKING CARE OF UNEXPECTED PROBLEMS

OIL PRESSURE INDICATOR GOES OFF AND ENGINE SPEED IS LIMITED

LHT Type (tiller handle)



*LRT and XRT Types
(remote control)*

**Side-Mount Control Type
(optional equipment)**

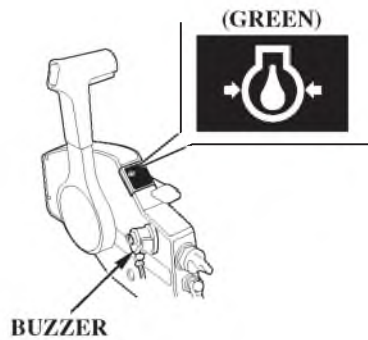

**Digital Tachometer
[optional equipment (LRT and XRT types)]**

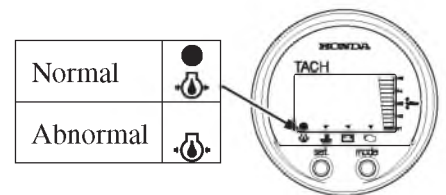

If oil pressure becomes low, the oil pressure indicator will go off, and the engine protection system limits engine speed. If you are at cruising speed, engine speed will decrease automatically.

The oil pressure indicator is also equipped with a buzzer that sounds when the oil pressure indicator goes off.

Low oil pressure may be the result of a low engine oil level, or there may be a problem with the engine lubrication system.

TAKING CARE OF UNEXPECTED PROBLEMS

If the throttle is closed suddenly after full throttle operation, engine speed may drop below the specified idle rpm, and that could activate the engine protection system momentarily.

If low oil pressure activates the engine protection system, stop the engine, check the engine oil level (p. 80), and add oil if needed.

With the engine oil at the recommended level, restart the engine. If the lubrication system is OK, the oil pressure indicator should come on within 30 seconds, and the engine will respond normally to throttle control lever operation.

If the engine protection system remains activated after 30 seconds, return to the nearest boat landing, and have the outboard motor inspected by an authorized Honda Marine dealer.

OVERHEAT INDICATOR COMES ON AND ENGINE SPEED IS LIMITED

LHT Type (tiller handle)

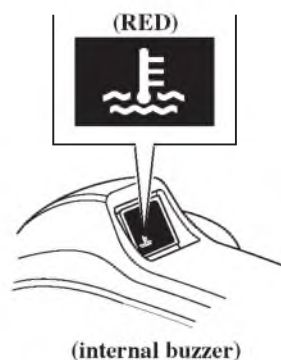

LRT and XRT Types (remote control)

Side-Mount Control Type (optional equipment)

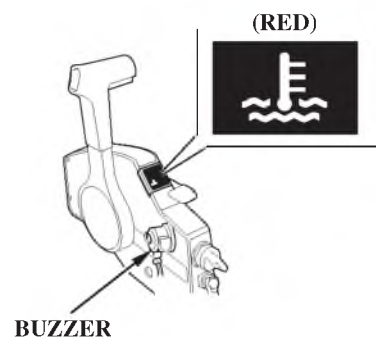

TAKING CARE OF UNEXPECTED PROBLEMS

Digital Tachometer [optional equipment (LRT and XRT types)]

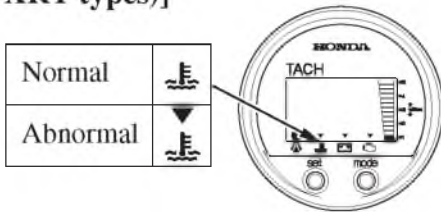

If the engine overheats, the overheat indicator will come on, and the engine will stop in 20 seconds after the engine protection system limits engine speed. If you are at cruising speed, engine speed will decrease automatically.

All types are equipped with a buzzer that sounds when the overheat indicator comes on.

Engine overheating may be the result of restricted water intake screens, or there may be a problem with the cooling system thermostat or water pump.

If the engine is stopped after running at full throttle, and then restarted soon afterward, that could activate the engine protection system momentarily.

COOLING SYSTEM INDICATOR

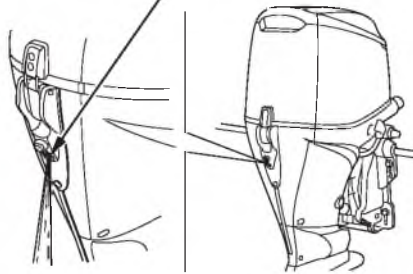

If overheating activates the engine protection system, idle the engine in neutral, and check the cooling system indicator.

If water is flowing from the cooling system indicator, continue idling for 30 seconds. If the cooling system is OK, the overheat indicator should go off within 30 seconds, and the engine will respond normally to throttle control lever operation.

If there is no water flowing from the cooling system indicator, stop the engine, and tilt the outboard motor to inspect the water intake screens. If restricted, clean the water intake screens, return the outboard motor to the running position, restart the engine, and check the cooling system indicator again.

If there is still no water flowing from the cooling system indicator, or if the engine protection system remains activated after 30 seconds, return to the nearest boat landing, and have the outboard motor inspected by an authorized Honda Marine dealer.

TAKING CARE OF UNEXPECTED PROBLEMS

SUBMERGED MOTOR

A submerged outboard motor must be serviced immediately after it is recovered from the water in order to minimize corrosion.

If there is a Honda Marine dealership nearby, take the motor to the dealer immediately. If you are far from a dealer, proceed as follows:

1. Remove the engine cover, and rinse the outboard motor with fresh water to remove salt water, sand, mud, etc.
2. Drain the vapor separator as described on p. 99 .

3. Change the engine oil as described on p. 81 — 82 . If there was water in the engine crankcase, or if the used engine oil showed signs of water contamination, then a second engine oil change should be performed after running the engine for half an hour.

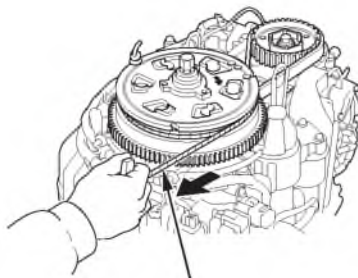

EMERGENCY STARTER ROPE

4. Remove the alternator cover (p. 56).

5. Remove the spark plugs (p. 83), and remove the emergency stop switch clip from the emergency stop switch. Pull the emergency starter rope, rotate the flywheel a few revolutions to completely expel any water from the engine's cylinders.

If the engine was running when it submerged, there may be mechanical damage, such as bent connecting rods. If the engine binds when cranked, do not attempt to run the engine until it has been repaired.

NOTICE

When cranking the engine with an open ignition circuit (spark plugs removed from the ignition circuit), remove the clip from the emergency stop switch to prevent possible damage to the ignition system.

TAKING CARE OF UNEXPECTED PROBLEMS

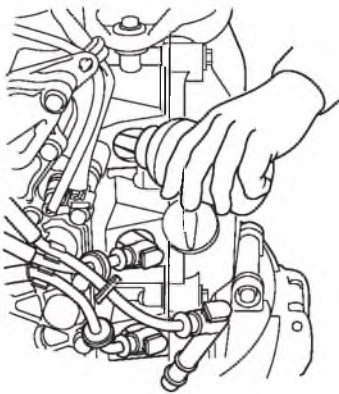

6. Pour a teaspoon of engine oil into each spark plug hole, then pull the emergency starter rope several times to lubricate the inside of the cylinders.
7. Reinstall the spark plugs and alternator cover, and put the emergency stop switch clip into the emergency stop switch.

8. Attempt to start the engine (be sure the water level is at least 2 inches above the antiventilation plate).

If you are changing the oil filter while the outboard motor is out of the water, use commercially available ear muffs and water hose to supply water.

NOTICE

Running the outboard motor without sufficient cooling water will damage the water pump and overheat the engine.

If the engine fails to start, remove the spark plugs and dry them, then reinstall the spark plugs and attempt to start the engine again.

If the engine starts, and no mechanical damage is evident, continue to run the engine for a half hour or longer. Be sure the water level is at least two inches above the antiventilation plate to avoid overheating and water pump

damage.

9. As soon as possible, take the outboard motor to an authorized Honda Marine dealer for inspection and service.

TECHNICAL AND CONSUMER INFORMATION

TECHNICAL INFORMATION

Serial Number Locations

Record the product identification number, the engine serial number, and the date of purchase in the space provided on this page. You will need these numbers when ordering parts, and when making technical or warranty inquiries (p. 126).

**PRODUCT
IDENTIFICATION
NUMBER**

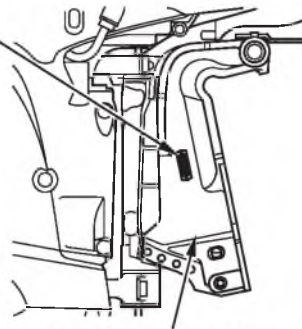

RIGHT STERN BRACKET

The engine serial number is stamped on the cylinder head on the back of the engine.

Product identification number:

Date of purchase:

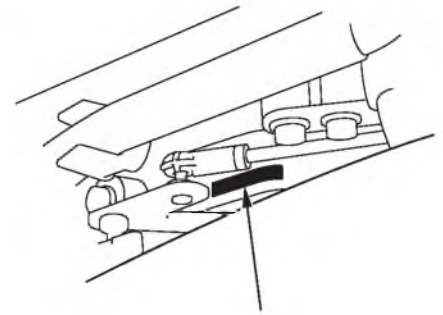

ENGINE SERIAL NUMBER

The engine serial number is stamped on the upper right side of the motor.

Engine serial number:

TECHNICAL AND CONSUMER INFORMATION

Battery

For complete information, refer to the battery manufacturer's instructions.

Minimum Requirements

12V – 52Ah/5HR (65Ah/20HR)
(CCA420A)

NOTICE

- *Be careful to avoid connecting the battery in reverse polarity, as this will damage the battery-charging system in the outboard motor.*
- *Do not disconnect the battery cables while the engine is running. Disconnecting the cables while the engine is running will damage the outboard motor's electrical system.*
- *Battery cable extension: Extending the original battery cable will cause the battery voltage to drop due to the increased length of the cable and number of connections. This voltage drop may cause the buzzer to sound momentarily when*

engaging the starter motor and may prevent the outboard from starting. If the outboard starts and the buzzer sounds momentarily, there may be barely sufficient voltage reaching the engine.

WARNING: Battery posts, terminals, and related accessories contain lead and lead compounds. **Wash your hands after handling.**

Emission Control System Information

Source of Emissions

The combustion process produces carbon monoxide, oxides of nitrogen, and hydrocarbons. Control of hydrocarbons and oxides of nitrogen is very important because, under certain conditions, they react to form photochemical smog when subjected to sunlight. Carbon monoxide does not react in the same way, but it is toxic.

Honda utilizes appropriate air/fuel ratios and other emissions control systems to reduce the emissions of carbon monoxide, oxides of nitrogen, and hydrocarbons.

Ignition Timing Control System

The system constantly adjusts the ignition timing, reducing the amount of HC, CO, and NO_x produced.

TECHNICAL AND CONSUMER INFORMATION

PGM-FI System

The PGM-FI system uses sequential multiport fuel injection. It has two subsystems: Engine Control, and Fuel Control. The Engine Control Module (ECM) uses various sensors to determine how much air is going into the engine. It then controls how much fuel to inject under all operating conditions.

The U.S. and California Clean Air Acts

EPA and California regulations require all manufacturers to furnish written instructions describing the operation and maintenance of emission control systems.

The following instructions and procedures must be followed in order to keep the emissions from your Honda engine within the emission standards.

Tampering and Altering

Tampering with or altering the emission control system may increase emissions beyond the legal limit. Among those acts that constitute tampering are:

- Removal or alteration of any part of the intake, fuel, or exhaust systems.
- Alterations that would cause the engine to operate outside its design parameters.

TECHNICAL AND CONSUMER INFORMATION

Problems That May Affect Emissions

If you are aware of any of the following symptoms, have your engine inspected and repaired by your servicing dealer.

- Hard starting or stalling after starting.
- Rough idle.
- Misfiring or backfiring under load.
- Afterburning (backfiring).
- Black exhaust smoke or high fuel consumption.

Replacement Parts

The emission control systems on your Honda engine were designed, built, and certified to conform with EPA and California emission regulations. We recommend the use of Honda Genuine parts whenever you have maintenance done. These original-design replacement parts are manufactured to the same standards as the original parts, so you can be confident of their performance. The use of replacement parts that are not of the original design and quality may impair the effectiveness of your emission control system.

A manufacturer of an aftermarket part assumes the responsibility that the part will not adversely affect emission performance. The manufacturer or rebuilder of the part must certify that use of the part will not result in a failure of the engine to comply with emission regulations.

Maintenance

Follow the maintenance schedule on p. 75 . Remember that this schedule is based on the assumption that your machine will be used for its designed purpose. Sustained high-load operation, or use in unusual conditions, will require more frequent service.

TECHNICAL AND CONSUMER INFORMATION

Star Label US, Puerto Rico, and US Virgin Islands

A Star label was applied to this outboard motor in accordance with the requirements of the California Air Resources Board.

The Star Label means Cleaner Marine Engine

This engine has been certified as a:



The Symbol for Cleaner Marine Engines:

Cleaner Air and Water - for healthier lifestyle and environment.

Better Fuel Economy - burns up to 30 - 40 percent less gas and oil than conventional carbureted two-stroke engines, saving money and resources.

Longer Emission Warranty - protects consumer for worry-free operation.

TECHNICAL AND CONSUMER INFORMATION



**One Star
Low
Emission**

The one-star label identifies engines that meet the Air Resources Board's Personal Watercraft and Outboard marine engine 2001 exhaust emission standards. Engines meeting these standards have 75% lower emissions than conventional carbureted two-stroke engines. These engines are equivalent to the U.S. EPA's 2006 standards for marine engines.



**Two Stars
Very Low
Emission**

The two-star label identifies engines that meet the Air Resources Board's Personal Watercraft and Outboard marine engine 2004 exhaust emission standards. Engines meeting these standards have 20% lower emissions than One Star-Low Emission engines.



**Three Stars
Ultra Low
Emission**

The three-star label identifies engines that meet the Air Resources Board's Personal Watercraft and Outboard marine engine 2008 exhaust emission standards or the Sterndrive and Inboard marine engine 2003-2008 exhaust emission standards. Engines meeting these standards have 65% lower emissions than One Star-Low Emission engines.



**Four Stars
Super Ultra
Low Emission**

The four-star label identifies engines that meet the Air Resources Board's Sterndrive and Inboard marine engine 2009 exhaust emission standards. Personal Watercraft and Outboard marine engines may also comply with these standards. Engines meeting these standards have 90% lower emissions than One Star-Low Emission engines.

Cleaner Watercraft - Get the Facts
1-800-END-SMOG
www.arb.ca.gov

TECHNICAL AND CONSUMER INFORMATION

Specifications

MODEL	BF60A		
Description code	BBFJ		
Type	LHT	LRT	XRT
Overall length	33.5 in (851 mm)	30.6 in (777 mm)	
Overall width	16.4 in (417 mm)		
Overall height	55.0 in (1,397 mm)		60.0 in (1,524 mm)
Transom height (when transom angle is 12°)	20.5 in (521 mm)		25.5 in (648 mm)
Dry mass [weight] *	254 lbs (115 kg)	243 lbs (110 kg)	256 lbs (116 kg)
Rated power	44.7 kW (60 HP)/5,500 rpm		
Full throttle range	5,000 – 6,000 rpm		
Engine type	4 stroke OHC in-line 3 cylinder		
Displacement	60.9 cu-in (998 cm ³)		
Spark plug gap	0.031 – 0.035 in (0.8 – 0.9 mm)		
Steering control system	Tiller handle	Motor-mounted, remote control	
Starter system	Electric starter		
Ignition system	Full transistor battery		
Lubrication system	Trochoid pump pressure lubrication		

Specified oil	Engine: API standard (SG, SH, SJ) SAE 10W-30 Gear case: API standard (GL-4) SAE 90 outboard motor gear oil
Oil capacity	Engine: 2.7 US qt (2.6 L) without oil filter change 2.9 US qt (2.7 L) with oil filter change Gear case: 0.45 US qt (0.43 L)
CARB star label	ULTRA · LOW EMISSION
D.C. output	12V – 20A
Cooling system	Water cooling with thermostat
Exhaust system	Water exhaust
Spark plugs	LMAR6C-9 (NGK)
Fuel pump	Low pressure side: mechanical type High pressure side: electrical type
Fuel	Unleaded gasoline (86 pump octane or higher)
Gear change	Dog type (Forward-Neutral-Reverse)
Steering angle	50° right and left
Trim angle	– 4° to 16° (when Transom angle is 12°)
Tilt up angle	60° (when Transom angle is 12°)
Transom angle	8°, 12°, 16°, 20°, 24°

* Without battery cable, with propeller

Honda outboards are power rated in accordance with NMMA procedures and using the ICOMIA standard 28/23.

TECHNICAL AND CONSUMER INFORMATION

Specifications

MODEL	BFP60A	
Description code	BBFJ	
Type	LRT	XRT
Overall length	31.2 in (792 mm)	
Overall width	16.4 in (417 mm)	
Overall height	57.2 in (1,453 mm)	62.2 in (1,580 mm)
Transom height (when transom angle is 12°)	20.9 in (531 mm)	25.9 in (658 mm)
Dry mass [weight] *	262 lbs (119 kg)	276 lbs (125 kg)
Rated power	44.7 kW (60 HP)/5,500 rpm	
Full throttle range	5,000 – 6,000 rpm	
Engine type	4 stroke OHC in-line 3 cylinder	
Displacement	60.9 cu-in (998 cm ³)	
Spark plug gap	0.031 – 0.035 in (0.8 – 0.9 mm)	
Steering control system	Motor-mounted, remote control	
Starter system	Electric starter	
Ignition system	Full transistor battery	
Lubrication system	Trochoid pump pressure lubrication	

Specified oil	Engine: API standard (SG, SH, SJ) SAE 10W-30 Gear case: API standard (GL-4) SAE 90 outboard motor gear oil
Oil capacity	Engine: 2.7 US qt (2.6 L) without oil filter change 2.9 US qt (2.7 L) with oil filter change Gear case: 1.00 US qt (0.95 L)
CARB star label	ULTRA · LOW EMISSION
D.C. output	12V – 20A
Cooling system	Water cooling with thermostat
Exhaust system	Water exhaust
Spark plugs	LMAR6C-9 (NGK)
Fuel pump	Low pressure side: mechanical type High pressure side: electrical type
Fuel	Unleaded gasoline (86 pump octane or higher)
Gear change	Dog type (Forward-Neutral-Reverse)
Steering angle	50° right and left
Trim angle	– 4° to 16° (when Transom angle is 12°)
Tilt up angle	60° (when Transom angle is 12°)
Transom angle	8°, 12°, 16°, 20°, 24°

* Without battery cable, with propeller

Honda outboards are power rated in accordance with NMMA procedures and using the ICOMIA standard 28/23.

TECHNICAL AND CONSUMER INFORMATION

BF60A/BFP60A Tune up

Spark plug gap	0.031–0.035 in (0.8–0.9 mm)	See page 83
Idle speed	850 ± 50 rpm	See shop manual
Valve clearance	Intake: 0.17 ± 0.02 mm Exhaust: 0.28 ± 0.02 mm	See shop manual
Other specifications	No other adjustment is needed	

TECHNICAL AND CONSUMER INFORMATION

CONSUMER INFORMATION

Honda Publications (United States, Puerto Rico, and U.S. Virgin Islands)

These publications will give you additional information for maintaining and repairing your outboard motor.

Shop Manual

This manual covers complete maintenance and overhaul procedures. It is intended to be used by a skilled technician.

Available through your Honda Marine dealer or through Helm Inc. at
1 888-292-5395 or
visit www.Honda-marine.com
and click on OWNERS.

Parts Catalog

This manual provides complete, illustrated parts lists. The catalog is available through your Honda Marine dealer.

Accessory Catalog

Your authorized Honda Marine dealer offers a wide selection of accessories (optional equipment, oils, and lubricants) to enhance your boating experience.

Visit www.honda-marine.com and click on accessories to see the entire catalog of accessories.

Customer Service Information

Contacting Honda

Your Owner's Manual was written to cover most of the questions you might ask about your Honda. Any questions not answered in the Owner's Manual can be answered by your Honda dealer. If your dealer doesn't have an immediate answer, they should be able to get it for you.

If you have a difference of opinion with your dealer, please remember that each dealership is independently owned and operated. That's why it's important to work to resolve any

differences at the dealership level. If the service personnel are unable to assist you, please discuss your concerns with the dealer management such as the Service Manager or the dealership's owner.

If you need to contact American Honda regarding your experiences with your Honda product or with your dealer, please send your comments to the following address:

American Honda Motor Co., Inc.
Marine Division
Customer Relations Office
4900 Marconi Drive
Alpharetta, GA 30005-8847
Telephone (770) 497-6400
M-F 8:30 am-7:00 pm (Eastern Time Zone)

Honda Canada Inc.
Customer Relations Office
Visit www.honda.ca for contact information
Tel: 1-888-946-6329 (Toll free)
Fax: 1-877-939-0909 (Toll free)

TECHNICAL AND CONSUMER INFORMATION

Please include the following information in your communication:

- Your name, address and telephone number (complete with area code)
- Model and complete serial number
- Date of purchase
- Name and location of selling dealer
- Name and location of servicing dealer (if different)
- A detailed description of your concerns

Warranty Coverage

Your new Honda is covered by the following warranties:

- Distributor's Limited Warranty
- Emission Control System Warranty

Please read the warranty statements contained in this manual. There are responsibilities, restrictions, and exclusions that apply to these warranties.

To obtain warranty service you must take your Honda outboard engine, together with proof of original retail purchase date, at your expense, to a Honda engine dealer or distributor authorized to sell that product in the United States, Puerto Rico, or the U.S. Virgin Islands.

It is important to realize that your warranty applies to defects in material or workmanship of your Honda. Your warranty coverage does not apply to normal wear or deterioration associated with using your Honda outboard.

Your warranty coverage will not be voided if you choose to perform your own maintenance. However, you should have the proper tools and service information and be mechanically qualified. Failures that occur due to modifications, improper maintenance, or service are not covered.

TECHNICAL AND CONSUMER INFORMATION

Warranty Service

Please remember that recommended maintenance interval servicing is not included in your warranty coverage. Additionally, your warranty does not apply to the normal wear of items (such as spark plug(s), water pump, etc.).

As the owner of a Honda product, your servicing dealer may ask you to authorize an inspection. If the problem is covered under warranty, your dealer will perform any warranty repairs for you at no cost. However, you may be responsible for additional non-warranty charges.

If you have questions about warranty coverage or the nature of the repair, it is best to talk to the service manager of your Honda dealer.

Sometimes, in spite of the best intentions of all concerned, a misunderstanding may occur. If you aren't satisfied with your dealer's

handling of the situation, we suggest you discuss your problem with the appropriate member of the dealership's management team. If the problem has already been reviewed with the appropriate manager of the Service, Parts, or Sales department, contact the owner of the dealership or their designated representative.

TECHNICAL AND CONSUMER INFORMATION

Warranty Statements

The American Honda Distributor's Limited Warranty applies to outboards purchased in the United States, Puerto Rico, or the U.S. Virgin Islands. The Honda Canada Distributor's Warranty applies to outboards purchased in Canada. The product warranty is only valid in the country where the product was purchased.

United states, Puerto Rico and Virgin Islands

Distributor's Limited Warranty

This warranty is limited to Honda Outboard Motors distributed by American Honda Motor Co., Inc., Power Equipment Division, 4900 Marconi Drive, Alpharetta, Georgia 30005-8847.

Products Covered by Warranty:	Length of Warranty: (from date of original retail purchase)		
	NONCOMMERCIAL/ NONRENTAL	COMMERCIAL/RENTAL	STATE/LOCAL/FEDERAL GOVERNMENT
All Models: Model Year 2000 and Newer*	36 months	12 months	24 months
Models BF115/BF130: All Model Years*	36 months	12 months	24 months
Models BF2 — BF90: Model Year 1999 and Earlier*	24 months	12 months	24 months
All Models purchased after July 1, 2008	60 months	12 months	24 months

*Models purchased prior to July 1, 2008 (unless previously purchased with True-5 warranty from a participating dealer).

To Qualify for This Warranty:

The Honda Outboard Motor must be purchased from American Honda or a dealer authorized by American Honda to sell Honda Outboard Motors in the United States, Puerto Rico, or the U.S. Virgin Islands. This limited warranty applies to the first retail purchaser and each subsequent owner during the applicable warranty time period.

What American Honda Will Repair or Replace Under Warranty:

American Honda will repair or replace, at its option, any part that is proven to be defective in material or workmanship under normal use during the applicable warranty time period. Warranty repairs and replacements will be made without charge for parts or labor. Anything replaced under warranty becomes the property of American Honda Motor Company, Inc.

TECHNICAL AND CONSUMER INFORMATION

All parts replaced under warranty will be considered as part of the original product and any warranty on those parts will expire coincidentally with the original product warranty.

To Obtain Warranty Service:

You must take your Honda Outboard Motor and proof of the original purchase date, at your expense, to any dealer who is authorized to service Honda Outboard Motors in the United States, Puerto Rico, or the U.S. Virgin Islands, during the dealer's normal business hours.

If you are unable to obtain warranty service, or are dissatisfied with the warranty service you receive, take the following steps: First, contact the owner of the dealership involved; normally this should resolve the problem. However, if you should require further assistance, write or call the Honda Marine Customer Relations. Please see *Contacting Honda* page 126 .

Exclusions:

This warranty does not extend to the following:

- Conditions caused by lack of routine maintenance (as outlined in the Owner's Manual)
- Conditions caused by the use of propeller (s) that do not allow the outboard motor to run in its recommended full throttle rpm range
- Operation inconsistent with the recommended operation/duty cycle (as outlined in the Owner's Manual)

- Parts affected or damaged by an accident, submersion and/or collision
- Normal wear and tear
- Fuel contamination and water entering engine through the fuel intake, air intake or exhaust system
- Operation with fuels, oils, additives and lubricants which are not suitable for use in the product
- Use in an application for which the outboard motor was not designed, such as racing or competitive use or any other misuse or neglect
- Incorporation of unsuitable attachments or parts
- The unauthorized alteration, improper installation and/or rigging, or any causes other than defects in material or workmanship
- Corrosion to steering system or electrical components, corrosion due to electrolysis, water born foreign chemicals, improper service or corrosion caused by damage or abuse
- Reimbursement for towing charges, in and out of water charges, or technician travel time
- Growth of marine organisms on motor surfaces, external or internal
- Any product that has ever been declared a total loss or sold for salvage by a financial institution or insurer, or that has been issued a "salvage" or similar title under any state's law.

TECHNICAL AND CONSUMER INFORMATION

Accessories and Replacement Parts

This warranty is limited to Honda Power Equipment parts, accessories and apparel when distributed by American Honda Motor Co., Inc., 1919 Torrance Blvd., Torrance, California 90501-2746.

Products Covered by Warranty:	Length of Warranty: (from date of original retail purchase)		
	Non Commercial	Commercial/Rental	Local/State/Federal Government
Accessories	12 months	3 months	3 months
Replacement Parts	6 months	3 months	3 months

To Qualify for This Warranty:

- The accessories or replacement parts must be purchased from American Honda, or a dealer, distributor or distributor's dealer authorized by American Honda to sell those products in the United States, Puerto Rico, and the U.S. Virgin Islands. Installing parts and accessories on non-Honda products or engines voids this warranty.
- You must be the first retail purchaser. This warranty is not transferable to subsequent owners.

What American Honda Will Repair or Replace Under Warranty:

American Honda will repair or replace, at its option, any marine product accessories or replacement parts that are proven to be defective in material or workmanship under normal use during the applicable warranty time period. Anything replaced under warranty becomes the property of American Honda Motor Company, Inc. All parts replaced under warranty will be considered as part of the original product and any warranty on those parts will expire coincidentally with the original product warranty.

Accessories and replacement parts, installed by a dealer who is authorized by American Honda to sell them, will be repaired or replaced under warranty without charge for parts or labor. If installed by anyone else, accessories and replacement parts will be repaired or replaced under warranty without charge for parts, but any labor charges will be the responsibility of the purchaser.

TECHNICAL AND CONSUMER INFORMATION

To Obtain Warranty Service:

You must take the Honda Outboard Motor product accessory or replacement part or the outboard motor or boat on which the accessory or replacement part is installed, and proof of purchase, at your expense, to any Honda Marine authorized service facility or dealer in the United States, Puerto Rico, or the U.S. Virgin Islands, during normal business hours.

Exclusions:

This warranty does not extend to accessories or parts affected or damaged by collision, normal wear, use in an application for which the product was not designed or any other misuse, neglect, incorporation or use of unsuitable attachments or parts, unauthorized alteration, improper installation, or any causes other than defects in material or workmanship of the product. Installing parts and accessories on non-Honda products or engines voids this warranty.

Disclaimer of consequential damage and limitation of implied warranties:

American Honda disclaims any responsibility for loss of time or use of the outboard motor, or the boat on which the product is installed, transportation, commercial loss, or any other incidental or consequential damage. Any implied warranties are limited to the duration of this written warranty. Some states do not allow limitations on

how long an implied warranty lasts and/or do not allow the exclusion or limitation of incidental or consequential damages, so the above exclusions and limitations may not apply to you. This warranty gives you specific legal rights, and you may also have other rights which vary from state to state.

TECHNICAL AND CONSUMER INFORMATION

Emission Control System Warranty

Your new Honda outboard engine complies with both the U.S. EPA and State of California emission regulations. American Honda provides the same emission warranty coverage for outboard engines sold in all 50 states.

YOUR WARRANTY RIGHTS AND OBLIGATION

California

The California Air Resources Board and American Honda Motor Co., Inc. are pleased to explain the emission control system warranty on your 2001 and later Honda outboard engine. In California, new outboard engines must be designed, built, and equipped to meet California's stringent anti-smog emission standards in addition to the U.S. EPA emissions standards.

All States

In all areas of the United States your outboard engine must be designed, built, and equipped to meet the U.S. EPA Emission Standard for spark ignited marine engines. American Honda Motor Co., Inc. must warranty the emission control system on your outboard engine for the period of time listed below provided there has been no abuse, neglect, or improper maintenance of your outboard engine. Where a warranty condition exists, American Honda Motor Co., Inc. will repair your

outboard engine at no cost to you including diagnosis, parts and labor.

Your emission control system may include such parts as the carburetor or fuel injection system and catalytic converter. Also included may be hoses, connectors and other emission-related assemblies.

MANUFACTURER'S EMISSION CONTROL SYSTEM WARRANTY COVERAGE:

Your 2010 and later outboard engine is warranted for a minimum of five years or 250 hours of operation, whichever comes first, or the length of Honda Marine Distributor's Limited warranty, whichever is longer. However, warranty coverage based on the hourly period is only permitted for outboard engines equipped with appropriate hour meters. If any emission-related part on your outboard engine is defective under warranty, the part will be repaired or replaced by American Honda Motor Co., Inc.

TECHNICAL AND CONSUMER INFORMATION

OWNER'S WARRANTY RESPONSIBILITY:

As the outboard engine owner, you are responsible for the performance of the required maintenance listed in your owner's manual. American Honda Motor Co., Inc. recommends that you retain all receipts covering maintenance on your outboard engine, but American Honda Motor Co., Inc. cannot deny warranty solely for the lack of receipts or for your failure to ensure the performance of all scheduled maintenance.

As the outboard engine owner, you should, however, be aware that American Honda Motor Co., Inc. may deny you warranty coverage if your outboard engine or a part has failed due to abuse, neglect, improper maintenance, or unapproved modifications.

You are responsible for presenting your outboard engine to a Honda Marine dealer as soon as a problem exists.

The warranty repair should be completed in a reasonable amount of time, not to exceed 30 days.

If you have any questions regarding your warranty rights and responsibilities, you should contact American Honda Motor Co., Inc., Marine Division Customer Relations Office. Please see *Contacting Honda* page 126 .

WARRANTY COVERAGE:

Honda outboard engines certified to the CARB and EPA 2010 regulations are covered by this warranty for a minimum of five years or 250 hours of operation, whichever comes first, or the length of the Honda Marine Distributor's Limited warranty, whichever is longer from the date of delivery to the retail purchaser. This warranty is transferred to each subsequent purchaser for the duration of the warranty period.

Warranty repairs will be made without charge for diagnosis, parts and labor. All defective parts replaced under this warranty become the property of American Honda Motor Co., Inc. A list of warranty parts is on page 136 . Normal maintenance items, such as spark plugs and filters, that are on the warranted parts list are warranted up to their required replacement interval only.

American Honda Motor Co., Inc. is also liable for damages to other engine components caused by a failure of any warranted part during the warranty period.

Only Honda approved replacement parts will be used in the performance of any warranty repairs and they will be provided without charge to the owner. The use of replacement parts not equivalent to the original parts may impair the effectiveness of your engine's emission control system. If such a replacement part is used in the repair or maintenance of your engine, and an authorized Honda Marine dealer determines it is defective or causes a failure of a warranted part, your claim for your engine

TECHNICAL AND CONSUMER INFORMATION

may be denied. If the part in question is not related to the reason that your engine requires repair, your claim will not be denied.

TO OBTAIN WARRANTY SERVICE:

You must take your Honda outboard engine, along with your sales registration card or other proof of original purchase date, at your expense, to any Honda Marine dealer who is authorized by American Honda Motor Co., Inc. to sell and service that Honda Marine product during his normal business hours. Claims for repair or adjustment found to be caused solely by defects in material or workmanship will not be denied because the engine was not properly maintained and used.

If you are unable to obtain warranty service, or are dissatisfied with the warranty service you received, contact the owner of the dealership involved. Normally this should resolve your problem. However, if you require further assistance, write or call the Honda Marine Customer Relations Office of American Honda Motor Co., Inc.

EXCLUSIONS:

Failures other than those resulting from defects in material or workmanship are not covered by this warranty. This warranty does not extend to emission control systems or parts which are affected or damaged by owner abuse, neglect, improper maintenance, misuse, misfueling, improper storage, and/or collision, the incorporation of, or use of, unsuitable attachments, or the unauthorized alteration of any part.

This warranty does not cover replacement of expendable maintenance items made in connection with required maintenance service after the item's first scheduled replacement as listed in the maintenance section of the product owner's manual, such as: spark plugs and filters.

DISCLAIMER OF CONSEQUENTIAL DAMAGE AND LIMITATION OF IMPLIED WARRANTIES:

American Honda Motor Co., Inc. disclaims any responsibility for incidental or consequential damages such as loss of time or the use of outboard engine, or any commercial loss due to the failure of the equipment; and any implied warranties are limited to the duration of this written warranty. This warranty is applicable only where the California or U.S. EPA emission control system warranty regulation is in effect.

TECHNICAL AND CONSUMER INFORMATION

EMISSION CONTROL SYSTEM WARRANTY PARTS:

SYSTEMS COVERED BY THIS WARRANTY:	PARTS DESCRIPTION
Fuel Metering	Carburetor assembly, Throttle body, Fuel injector, Fuel pump, Fuel pressure regulator, Throttle position sensor, Intake air temperature sensor, Engine temperature sensor, Manifold absolute pressure sensor, Idle air control valve, Barometric pressure sensor, Fuel line solenoid valve, Intake manifold, Intake valves, and Oxygen sensor or Air fuel ratio sensor
Evaporative	Portable fuel tank, Fuel cap, Fuel hoses, Primer bulb, Fuel hose joint
Air Induction	Air intake duct, Vapor separator, Intake manifold tuning valve (Intake air bypass control valve)
Ignition	Flywheel magneto, Ignition pulse generator, Ignition coil assembly, Ignition control module, Engine control module, Crankshaft position sensor, Spark plug cap, Spark plug*, Knock sensor, and Camshaft position sensor
Lubrication system	Oil pump and internal parts
Crankcase Emission Control	Crankcase breather tube, Positive crankcase ventilation valve, Oil filler cap
Exhaust	Exhaust manifold and Exhaust valves
Valve Control System	Rocker arm oil control valve
Miscellaneous Parts	Tubing, fittings, seals, gaskets, and clamps associated with these listed systems.
*Covered up to the first required replacement only. See the Maintenance Schedule on page 75.	

TECHNICAL AND CONSUMER INFORMATION

Canada

Distributor's Warranty

HONDA CANADA INC., for and on behalf of Honda Motor Co. Ltd., Tokyo, Japan, gives the following written warranty on each new marine product manufactured by Honda Motor Co. Ltd., Japan, distributed in Canada by Honda Canada Inc. and sold by authorized Honda Marine dealers.

Whenever used herein, the word "Honda" refers to Honda Canada Inc. and/or Honda Motor Co. Ltd., as appropriate from the context.

HONDA WARRANTS THAT each new Honda marine product will be free, under normal use and maintenance, from any defects in material or workmanship for the relevant warranty period set forth below. If any defects should be found in a Honda marine product within the relevant warranty period, necessary repairs and replacements with a new part or the Honda equivalent shall be made at no cost to the consumer for parts and labour, when Honda acknowledges that such defects are attributable to faulty material or workmanship at the time of manufacture.

WARRANTY PERIOD RETAILED ON OR AFTER APRIL 1, 2005:

	Non-commercial use	Commercial use
All Honda Outboard Models	36 Months	12 Months

THIS WARRANTY COVERS

- a) Any Honda marine product purchased in Canada from an authorized Honda dealer which has been registered at the time of purchase on a form provided by Honda, which has had set-up and pre-delivery service performed by an authorized Honda dealer and which is normally operated in Canada;
- b) Any factory installed part (except normal maintenance parts referred to in "THIS WARRANTY DOES NOT COVER"); and
- c) Any marine product on which required maintenance services have been performed as prescribed in the Owner's Manual.

TECHNICAL AND CONSUMER INFORMATION

THIS WARRANTY DOES NOT COVER

- a) Any repairs required as a result of collision, accident, striking any object, misuse or lack of required maintenance;
- b) Any repairs required as a result of any attachments, parts or devices installed by or repairs done by a party other than an authorized Honda dealer;
- c) Any outboard that has been operated out of water, (Run Dry) damaging the water pump and or engine components due to insufficient cooling water.
- d) Any marine products modified, altered, disassembled or remodelled;
- e) Normal maintenance services, including tightening of nuts, bolts and fittings and engine tune-up and the replacement of parts made in connection with normal maintenance services including filters, spark plugs and wires, fuses, belts, lubricants and other expendables susceptible to natural wear;
- f) Outboard propeller or shear pin.
- g) All accessories or attachments.

THE OWNER'S OBLIGATION

In order to maintain the validity of this DISTRIBUTORS WARRANTY, the required maintenance services as set forth in the Owner's Manual must be performed at the proper intervals and detailed receipts and records retained as proof.

TO OBTAIN WARRANTY SERVICE

You must take your Honda marine product, at your expense, during normal service hours, to any authorized Honda Marine dealership. If you are unable to obtain or are dissatisfied with the warranty service you receive, first contact the owner of the dealership involved; this should resolve the problem. If you require further assistance, contact Honda Canada's Customer Relations Department at:

HONDA CANADA INC.

Visit www.honda.ca for address/contact information.

TELEPHONE: 1-888-946-6329 TOLL FREE

FAX : 1-877-939-0909 TOLL FREE

TECHNICAL AND CONSUMER INFORMATION

REPLACEMENT PARTS AND ACCESSORY WARRANTY

New genuine Honda replacement parts or accessories sold to a consumer or installed by an authorized Honda Marine dealer which are not covered by the DISTRIBUTORS WARRANTY are warranted for a period of one year from date of purchase, provided, however, that this Replacement Parts and Accessory Warranty does not apply to any replacement parts modified, used with, or installed on a marine product for which the replacement parts were not installed. Electrical components that are not installed by the dealer (sold over the counter) are not covered by warranty.

ENTIRE WRITTEN WARRANTY

This DISTRIBUTORS WARRANTY and the REPLACEMENT PARTS AND ACCESSORY WARRANTY are the only and the entire written warranties given by Honda for Marine engines. No dealer or his agent or employee is authorized to extend or enlarge on these warranties on behalf of Honda by any written or verbal statement or advertisement.

DISCLAIMER

To the extent the law permits, Honda disclaims any responsibility for loss of time or use of the product, transportation or towing costs or any other indirect, incidental or consequential damage, inconvenience or commercial loss.

NOTICE TO CONSUMER

The provisions contained in these written warranties are not intended to limit, modify, take away from, disclaim or exclude any warranties set forth in or the operation of The Consumer Products Warranties Act, 1977 (Saskatchewan), The Consumer Product Warranty and Liability Act (New Brunswick), The Consumer Protection Act (Quebec), or any other similar provincial or federal legislation.

INDEX

Alternator (ACG) Indicator.....	37	Electric Starter Will Not Operate.....	109
Anodes.....	42	EMERGENCY	
Replacement.....	93	STARTER ROPE.....	74
ARE YOU READY TO GET UNDERWAY?.....	43	STARTING.....	56
Battery.....	118	Emergency Stop Switch Clip and Emergency Stop	
Will Not Charge.....	109	Switch	
BEFORE OPERATION.....	43	LHT Type.....	22
BREAK-IN PROCEDURE.....	46	Side-Mount Control Type.....	27
Common Controls.....	30	Emission Control System Information.....	118
COMPONENT AND CONTROL LOCATIONS.....	14	Emission Control System Warranty.....	133
CONSUMER INFORMATION.....	126	Engine	
CONTROL AND FEATURE IDENTIFICATION		Cover	
CODES.....	13	Latches (front/rear).....	33
CONTROLS.....	22	REMOVAL AND INSTALLATION.....	79
CONTROLS AND FEATURES.....	13	Oil	
Cooling System Indicator.....	39	Change.....	81
CRUISING.....	65	Level Check.....	80
Customer Service Information.....	126	Recommendations.....	82
Digital Speedometer (optional equipment).....	36	OVERHEATS.....	108
Digital Tachometer (optional equipment).....	35	WILL NOT START.....	104
Distributor's Limited Warranty.....	129		
Distributor's Warranty.....	137		

INDEX

Fast Idle Lever.....	29	Ignition Switch	
Fuel		LHT Type.....	22
Filler Cap Vent Knob (optional equipment).....	41	LRT and XRT Types	
Filter/Water Separator Inspection and Service	89	Side-Mount Control Type	26
Gauge (optional equipment).....	36	IMPORTANT SAFETY INFORMATION	7
HOSE CONNECTIONS	48	INDICATORS.....	37
PRIMING	49	INSTRUMENTS.....	35
Priming Bulb	41	IS YOUR OUTBOARD MOTOR	
RECOMMENDATIONS	88	READY TO GO?.....	43
Fuse Replacement	110	Lubrication Points	85
FUSES.....	109	MAINTENANCE SAFETY	73
Gearshift Lever (LHT Type).....	24	MAINTENANCE SCHEDULE	75
Gearshift/Throttle Control Lever		Malfunction Indicator	37
(LRT and XRT Types)		MANUAL RELIEF VALVE.....	32, 79
Side-Mount Control Type	28	MOORING, BEACHING, LAUNCHING.....	70
GEARSHIFT AND THROTTLE OPERATION	62	NMEA Interface Coupler.....	41
HARD STARTING OR STALLS AFTER			
STARTING.....	107		
HOISTING THE OUTBOARD MOTOR.....	101		
Honda Publications	126		

INDEX

Oil Pressure Indicator.....	38	SAFE OPERATING PRECAUTIONS	46
OIL PRESSURE INDICATOR GOES OFF AND ENGINE SPEED IS LIMITED	112	SAFETY LABEL LOCATION	9
OPERATION	46	Serial Number Locations.....	117
OTHER FEATURES	40	SERVICING YOUR OUTBOARD MOTOR.....	72
OUTBOARD MOTOR SAFETY.....	7	SHALLOW WATER OPERATION.....	69
Overheat Indicator.....	39	Spark Plug Service	83
OVERHEAT INDICATOR COMES ON AND ENGINE SPEED IS LIMITED	113	Specifications.....	123
Overrev Limiter.....	40	Star Label	121
PORTABLE FUEL TANK (optional equipment)... 40, 47 and Tank Filter Cleaning (optional equipment).....	92	STARTING THE ENGINE	50
Power Tilt Switch (engine pan)	31	LHT Type.....	50
Power Trim/Tilt Switch	30	LRT and XRT Types Side-Mount Control Type.....	53
Propeller Replacement	94	STEERING.....	64
REFUELING.....	87	Steering Friction Adjuster (LHT Type).....	25, 64
REMOVAL FROM STORAGE.....	102	STOPPING THE ENGINE.....	59
Rudder meter [standard equipment (BFP60A LRTB type)], [optional equipment (other LRT and XRT types)].....	36	Emergency Engine Stopping.....	59
		Normal Engine Stopping.....	60
		STORAGE	96
		STORAGE PRECAUTIONS	101
		STORAGE PREPARATION.....	96
		Cleaning and Flushing	96
		Engine oil	101
		Fuel.....	98
		SUBMERGED MOTOR	115

INDEX

Tachometer (optional equipment).....	35	Trolling Speed Control	
TAKING CARE OF UNEXPECTED PROBLEMS...	104	[standard equipment (LHTC and LRTB types)],	
TECHNICAL AND CONSUMER		[optional equipment (except LHTC and LRTB	
INFORMATION.....	117	types)].....	67
TECHNICAL INFORMATION.....	117	Warranty Statements	129
THE IMPORTANCE OF MAINTENANCE.....	72		
Throttle			
Friction Adjuster (LHT Type).....	24		
Grip (LHT Type).....	23		
Tiller Handle Height/Angle Adjustment (LHT Type)...	45		
Tilt Lock Lever.....	33		
TOOL KIT and OWNER'S MANUAL.....	74		
TRANSPORTING	103		
WITH OUTBOARD MOTOR INSTALLED			
ON BOAT	103		
WITH OUTBOARD MOTOR REMOVED			
FROM BOAT	103		
Trim Meter (optional equipment)	35		
Trim Tab.....	34		
TRIM TAB ADJUSTMENT	77		
TRL (Trolling) Control Switch			
[standard equipment (LHTC and LRTB types)],			
[optional equipment (except LHTC and LRTB			
types)].....	32		

По вопросам продаж и поддержки обращайтесь:

Архангельск (8182)63-90-72
Астана +7(7172)727-132
Белгород (4722)40-23-64
Брянск (4832)59-03-52
Владивосток (423)249-28-31
Волгоград (844)278-03-48
Вологда (8172)26-41-59
Воронеж (473)204-51-73
Екатеринбург (343)384-55-89
Иваново (4932)77-34-06
Ижевск (3412)26-03-58
Казань (843)206-01-48

Калининград (4012)72-03-81
Калуга (4842)92-23-67
Кемерово (3842)65-04-62
Киров (8332)68-02-04
Краснодар (861)203-40-90
Красноярск (391)204-63-61
Курск (4712)77-13-04
Липецк (4742)52-20-81
Магнитогорск (3519)55-03-13
Москва (495)268-04-70
Мурманск (8152)59-64-93
Набережные Челны (8552)20-53-41

Нижний Новгород (831)429-08-12
Новокузнецк (3843)20-46-81
Новосибирск (383)227-86-73
Орел (4862)44-53-42
Оренбург (3532)37-68-04
Пенза (8412)22-31-16
Пермь (342)205-81-47
Ростов-на-Дону (863)308-18-15
Рязань (4912)46-61-64
Самара (846)206-03-16
Санкт-Петербург (812)309-46-40
Саратов (845)249-38-78

Смоленск (4812)29-41-54
Сочи (862)225-72-31
Ставрополь (8652)20-65-13
Тверь (4822)63-31-35
Томск (3822)98-41-53
Тула (4872)74-02-29
Тюмень (3452)66-21-18
Ульяновск (8422)24-23-59
Уфа (347)229-48-12
Челябинск (351)202-03-61
Череповец (8202)49-02-64
Ярославль (4852)69-52-93

www.honda.nt-rt.ru || hdn@nt-rt.ru